



⚠ WARNING

- Installation must be performed by qualified personnel and in accordance with all national and local codes and ordinances.
- Shock hazard. Disconnect power source before servicing. Serious injury or death could result.
- Risk of explosion. Not for use in hazardous locations. Serious injury or death could result.

UL, CUL and CSFM Listed, FM Approved, LPCB Approved, For CE Marked (EN12259-5)/VdS Approved model use VSR-EU

Service Pressure: 450 PSI (31 BAR) - UL

Flow Sensitivity Range for Signal:

4-10 GPM (15-38 LPM) - UL

Maximum Surge: 18 FPS (5.5 m/s)

Contact Ratings: Two sets of SPDT (Form C)
10.0 Amps at 125/250VAC
2.0 Amps at 30VDC Resistive
10 mAmps min. at 24VDC

Conduit Entrances: Two knockouts provided for 1/2" conduit.
Individual switch compartments suitable for dissimilar voltages.

Environmental Specifications:

- NEMA 4/IP54 Rated Enclosure suitable for indoor or outdoor use with factory installed gasket and die-cast housing when used with appropriate conduit fitting.
- Temperature Range: 40°F - 120°F, (4.5°C - 49°C) - UL
- Non-corrosive sleeve factory installed in saddle.

Service Use:

Automatic Sprinkler	NFPA-13
One or two family dwelling	NFPA-13D
Residential occupancy up to four stories	NFPA-13R
National Fire Alarm Code	NFPA-72

Optional: Cover Tamper Switch Kit, stock no. 0090148

Replaceable Components: Retard/Switch Assembly, stock no. 1029030

General Information

The Model VSR is a vane type waterflow switch for use on wet sprinkler systems. It is UL Listed and FM Approved for use on steel pipe; schedules 10 through 40, sizes 2" thru 8" (50 mm thru 200 mm). LPC approved sizes are 2" thru 8" (50 mm thru 200 mm). See Ordering Information chart.

The VSR may also be used as a sectional waterflow detector on large systems.

The VSR contains two single pole, double throw, snap action switches and an adjustable, instantly recycling pneumatic retard. The switches are actuated when a flow of 10 GPM (38 LPM) or more occurs downstream of the device. The flow condition must exist for a period of time necessary to overcome the selected retard period.

Enclosure

The VSR switches and retard device are enclosed in a general purpose, die-cast housing. The cover is held in place with two tamper resistant screws which require a special key for removal. A field installable cover tamper switch is available as an option which may be used to indicate unauthorized removal of the cover. See bulletin number 5401103 for installation instructions of this switch.

Installation (See Fig. 1)

These devices may be mounted on horizontal or vertical pipe. On horizontal pipe they should be installed on the top side of the pipe where they will be accessible. The device should not be installed within 6" (15 cm) of a fitting which changes the direction of the waterflow or within 24" (60 cm) of a valve or drain.

Note: Do not leave cover off for an extended period of time.

Drain the system and drill a hole in the pipe using a hole saw in a slow speed drill. (see Fig. 1)

Clean the inside pipe of all growth or other material for a distance equal to the pipe diameter on either side of the hole.

Roll the vane so that it may be inserted into the hole; do not bend or crease it. Insert the vane so that the arrow on the saddle points in the direction of the waterflow. Install the saddle strap and tighten nuts alternately to required torque. (see Fig. 1). The vane must not rub the inside of the pipe or bind in any way.

Specifications subject to change without notice.

Ordering Information			
Nominal Pipe Size		Model	Part Number
2"	DN50	VSR-2	1144402
2 1/2"	DN65	VSR-2 1/2	1144425
3"	DN80	VSR-3	1144403
3 1/2"	-	VSR-3 1/2	1144435
4"	DN100	VSR-4	1144404
5"	-	VSR-5	1144405
6"	DN150	VSR-6	1144406
8"	DN200	VSR-8	1144408

Fig. 1

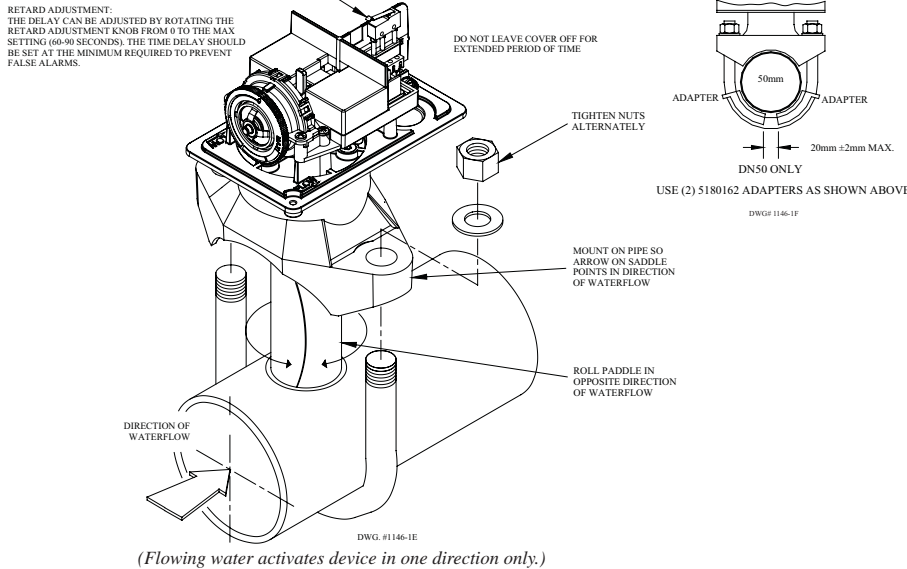
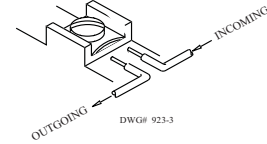

Fig. 2 Switch Terminal Connections
Clamping Plate Terminal



WARNING

An uninsulated section of a single conductor should not be looped around the terminal and serve as two separate connections. The wire must be severed, thereby providing supervision of the connection in the event that the wire become dislodged from under the terminal. Failure to sever the wire may render the device inoperable risking severe property damage and loss of life.

CAUTION

Waterflow switches that are monitoring wet pipe sprinkler systems should not be used as the sole initiating device to discharge AFFF, deluge, or chemical suppression systems. Waterflow switches used for this application may result in unintended discharges caused by surges, trapped air, or short retard times.

Installation Requirements

Model	Nominal Pipe Size		Nominal Pipe O.D.		Hole Size		U-Bolt Nuts Torque	
	inch	mm	inch	mm	inch	mm	ft-lb	n-m
VSR-2	2	DN50	2.375	60.3	1.25 + .125/-062	33.0 ± 2.0	20	27
VSR-2 1/2	2 1/2		2.875	73.0				
VSR-2 1/2	2 1/2	DN65	3.000	76.1				
VSR-3	3	DN80	3.500	88.9	2.00 ± .125	50.8 ± 2.0		
VSR-3 1/2	3 1/2		4.000	101.6				
VSR-4	4	DN100	4.500	114.3				
VSR-5	5		5.563	141.3				
VSR-6	6	DN150	6.625	168.3				
VSR-8	8	DN200	8.625	219.1				

Fig. 3 Typical Electrical Connections

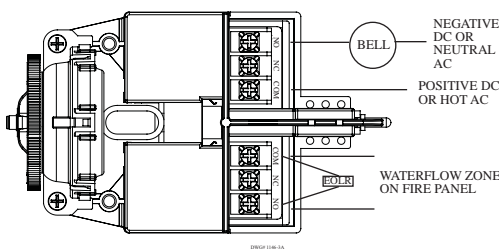

Notes:

1. The Model VSR has two switches, one can be used to operate a central station, proprietary or remote signaling unit, while the other contact is used to operate a local audible or visual annunciator.
2. A condition of LPC Approval of this product is that the electrical entry must be sealed to exclude moisture.
3. For supervised circuits see "Switch Terminal Connections" drawing and caution note (Fig. 2).

Fig. 4

Break out thin section of cover when wiring both switches from one conduit entrance.

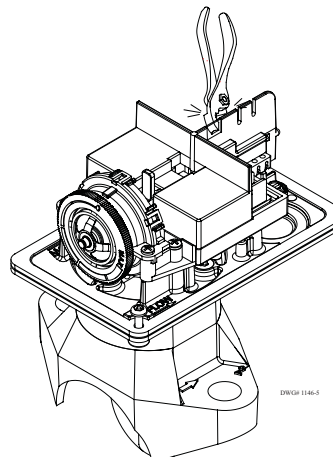
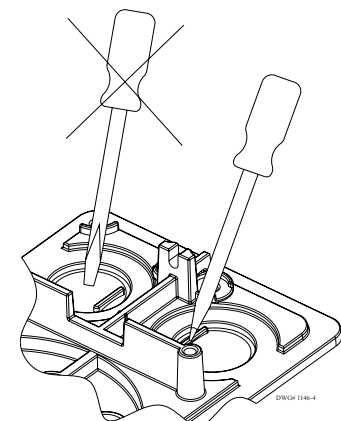

Fig. 5

To remove knockouts: Place screwdriver at inside edge of knockouts, not in the center.



Model	Nominal Pipe Size		Nominal Pipe O.D.		Compatible Pipe							
					Pipe Wall Thickness				DN (VDS)			
	inch	mm	inch	mm	Schedule 10 (UL)		Schedule 40 (UL)		BS-1387 (LPC)		DN (VDS)	
VSR-2	2	DN50	2.375	60.3	0.109	2.77	0.154	3.91	0.142	3.6	0.091	2.3
VSR-2 1/2	2 1/2		2.875	73.0	0.120	3.05	0.203	5.16				
VSR-2 1/2		DN65	3.000	76.1					0.142	3.6	0.102	2.6
VSR-3	3	DN80	3.500	88.9	0.120	3.05	0.216	5.49	0.157	4.0	0.114	2.9
VSR-3 1/2	3 1/2		4.000	101.6	0.120	3.05	0.226	5.74				
VSR-4	4	DN100	4.500	114.3	0.120	3.05	0.237	6.02	0.177	4.5	0.126	3.2
VSR-5	5		5.563	141.3	0.134	3.40	0.258	6.55				
VSR-6	6	DN150	6.625	168.3	0.134	3.40	0.280	7.11	0.197	5.0	0.157	4.0
VSR-8	8	DN200	8.625	219.1	0.148	3.76	0.322	8.18	0.248	6.3	0.177	4.5

Note: For copper or plastic pipe use Model VSR-CF.

Testing

The frequency of inspection and testing for the Model VSR and its associated protective monitoring system should be in accordance with applicable NFPA Codes and Standards and/or the authority having jurisdiction (manufacturer recommends quarterly or more frequently).

If provided, the inspector's test valve, that is usually located at the end of the most remote branch line, should always be used for test purposes. If there are no provisions for testing the operation of the flow detection device on the system, application of the VSR is not recommended or advisable. A minimum flow of 10 GPM (38 LPM) is required to activate this device.

Maintenance

Inspect detectors monthly for leaks. If leaks are found, replace the detector. The VSR waterflow switch should provide years of trouble-free service. The retard and switch assembly are easily field replaceable. In the unlikely event that either component does not perform properly, please order replacement retard switch assembly stock #1029030. There is no maintenance required, only periodic testing and inspection.

Removal

- To prevent accidental water damage, all control valves should be shut tight and the system completely drained before waterflow detectors are removed or replaced.
- Turn off electrical power to the detector, then disconnect wiring.
- Loosen nuts and remove U-bolts.
- Gently lift the saddle far enough to get your fingers under it. With your fingers, roll the vane so it will fit through the hole while continuing to lift the waterflow detector saddle.
- Lift detector clear of pipe.

Important Notice

Please advise the person responsible for testing of the fire protection system that this system must be tested in accordance with the testing instructions.

Mounting Dimensions

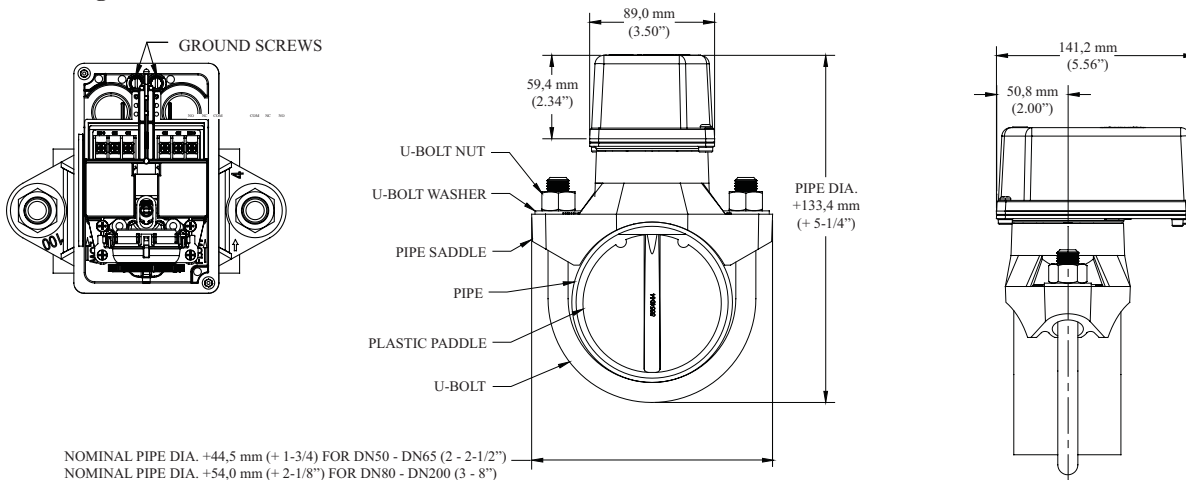

DWG# 1146-6