



Stock number - 1010080

**CAUTION**

This device is not intended for applications in explosive environments.

**UL, cUL and CSFM Listed, FM Approved and NYMEA Accepted, CE Marked, VdS Approved**

**Dimensions:** 5 9/16" H x 3 1/2" W x 5 7/8" D  
(14,1cm H x 8,9cm W x 14,9cm D)

**Weight:** 1.5 lbs. (3,3 kg.)

**Enclosure:** Cover - Die-cast with textured red powdercoat finish  
Base - Die-cast aluminum

**Pressure Connection:** 1/2" Male NPT

**Pressure Adjustments:** Factory adjusted to operate between 5 and 8 PSI (0.35 and 0,55 BAR) on rising pressure

**Maximum system pressure:** 175 PSI (12,1 BAR)

**Contact Ratings:** Two Sets of SPDT (Form C)  
15.0 Amps at 125/250VAC  
2.0 Amps at 30VDC Resistive

**Conduit Entrances:** Two knockouts provided for 1/2" conduit

**Environmental Specifications:** 40°F to 120°F (4,5°C to 49°C)  
NEMA 4 Enclosure - when used with proper conduit fittings

**Service Use:** Automatic Sprinkler NFFPA-13  
One or two family dwelling NFFPA-13D  
Residential occupancy up to four stories NFFPA-13R  
National Fire Alarm Code NFFPA-72

**Tamper:** Cover incorporates tamper resistant fasteners that require a special key for removal. One key is supplied with each device. For optional cover tamper switch kit, order Stock No. 0090018.

**Waterflow Alarm Switch With Retard For Supervision Of Wet Alarm Check Valve**

The Model WFSR-F is a pressure operated switch with an adjustable, instantly recycling pneumatic retard to prevent false alarms due to water pressure variation. The WFSR-F is connected into the alarm port of a wet sprinkler system alarm check valve (see "WARNING", page 2).

**Installation**

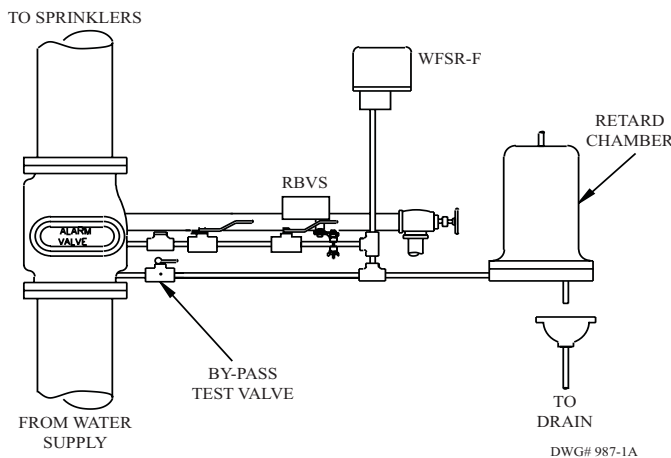
A male 1/2" NPT pipe fitting is provided for connection to the alarm port of the alarm check valve. No additional mounting or support is

required. Allow 5" (12,7cm) to the front of the unit for removal of the cover. Install with the pressure connection down.

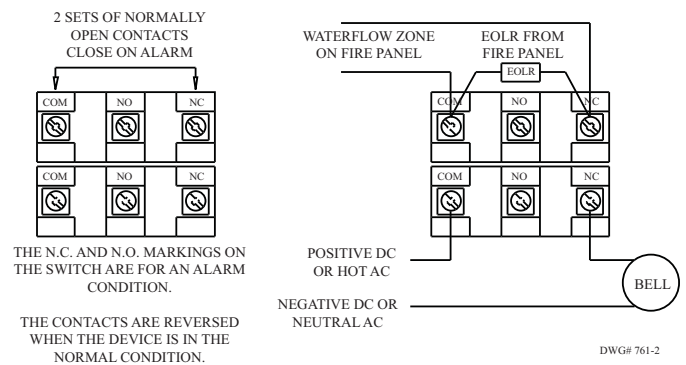
**Testing**

Operation of the unit is checked by opening the by-pass test valve or inspector's test valve. The frequency of the inspection and testing for the Model WFSR-F and its associated protective monitoring system should be in accordance with applicable NFFPA Codes and Standards and/or authority having jurisdiction (manufacturer recommends quarterly or more frequently).

**Fig. 1 WFSR-F**

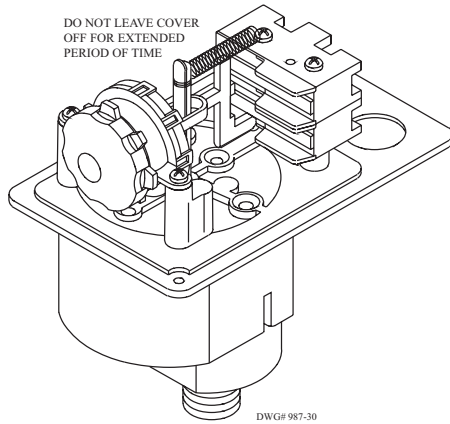


**Fig. 2 Typical Electrical Connections**



**Note:** For supervised circuits see "Switch Terminal Connections" drawing and caution note (Fig. 4).

Fig. 3

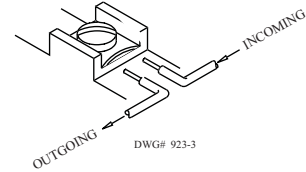


**Retard Adjustment:**

To change time turn knob (either direction) for desired time delay. Use the minimum amount of retard necessary to prevent false alarms, a "B" setting is usually adequate for this. Factory set at "B".

APPROX. RETARD SETTINGS (IN SEC.)					
0	A	B	C	D	E
0	10-25	20-40	35-55	50-70	60-90

Fig. 4 Switch Terminal Connections  
Clamping Plate Terminal



**CAUTION**

An uninsulated section of a single conductor should not be looped around the terminal and serve as two separate connections. The wire must be severed, thereby providing supervision of the connection in the event that the wire becomes dislodged from under the terminal.

Fig. 5 Typical Wet System

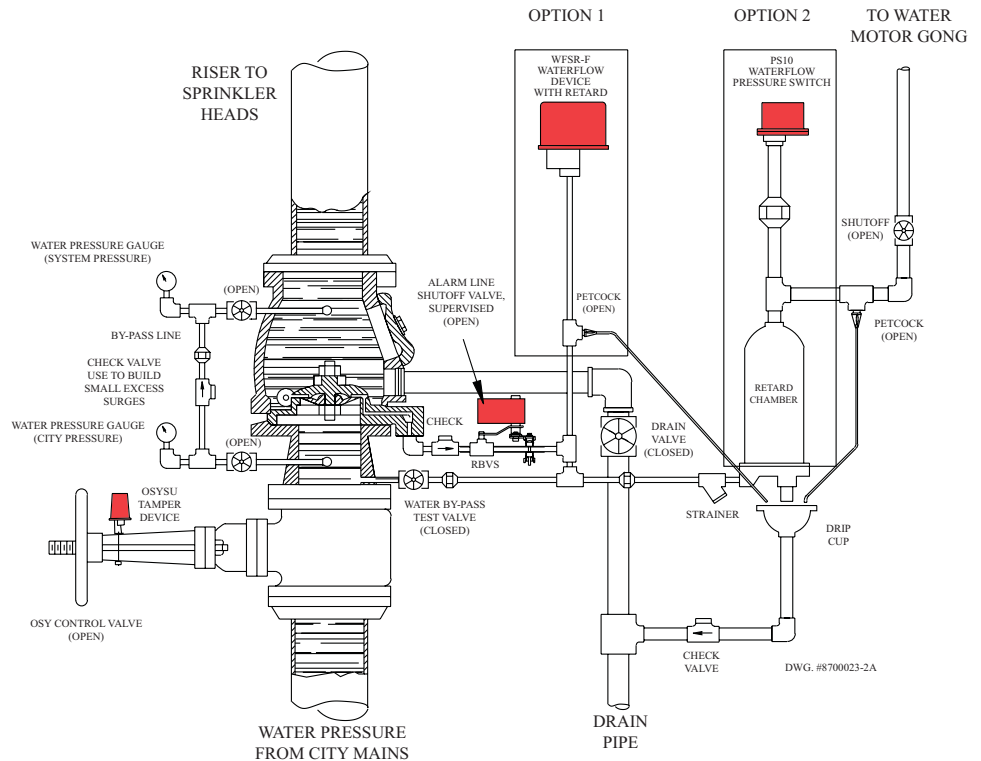
**WARNING**

Use teflon tape sealant only. Apply only to male threads of connectors.

Use of pipe cement voids warranty as this material may obstruct pressure aperture resulting in loss of alarm signal.

Device must be installed before any shut off valve on alarm port line unless it is supervised by a supervisory switch such as Potter Model RBVS.

The system should be tested on a quarterly basis or more frequently to insure proper operation.



**WARNING**

Due to the possibility of unintended discharges caused by pressure surges, trapped air, or short retard times, waterflow switches that are monitoring wet pipe sprinkler systems should not be used as the sole initiating device to discharge AFFF, deluge, or chemical suppression systems.