

Series TY-FRB — 5.6 K-factor Horizontal and Vertical Sidewall Sprinklers Quick Response, Standard Coverage

General Description

The Series TY-FRB, 5.6 K-Factor, Horizontal and Vertical Sidewall Sprinklers described in this data sheet are quick response - standard coverage, decorative 3 mm glass bulb type spray sprinklers designed for use in light and ordinary hazard, commercial occupancies such as banks, hotels, shopping malls, etc. They are designed for installation along a wall or the side of a beam and just beneath a smooth ceiling. Sidewall sprinklers are commonly used instead of pendent or upright sprinklers due to aesthetics or building construction considerations, where piping across the ceiling is not desirable.

The recessed version of the Series TY-FRB Horizontal Sidewall Sprinkler is intended for use in areas with a finished wall. It uses a two-piece Style 10 Recessed Escutcheon with 1/2 inch (12,7 mm) of recessed adjustment or up to 3/4 inch (19,1 mm) of total adjustment from the flush sidewall position, or a two-piece Style 20 Recessed Escutcheon with 1/4 inch (6,4 mm) of recessed adjustment or up to 1/2 inch (12,7 mm) of total adjustment from the flush sidewall position. The adjust-

ment provided by the Recessed Escutcheon reduces the accuracy to which the fixed pipe nipples to the sprinklers must be cut.

Corrosion resistant coatings, where applicable, are utilized to extend the life of copper alloy sprinklers beyond that which would otherwise be obtained when exposed to corrosive atmospheres. Although corrosion resistant coated sprinklers have passed the standard corrosion tests of the applicable approval agencies, the testing is not representative of all possible corrosive atmospheres. Consequently, it is recommended that the end user be consulted with respect to the suitability of these coatings for any given corrosive environment. The effects of ambient temperature, concentration of chemicals, and gas/chemical velocity, should be considered, as a minimum, along with the corrosive nature of the chemical to which the sprinklers will be exposed.

WARNINGS

The Series TY-FRB Sprinklers described herein must be installed and maintained in compliance with this document, as well as with the applicable standards of the National Fire Protection Association, in addition to the standards of any other authorities having jurisdiction. Failure to do so may impair the performance of these devices.

The owner is responsible for maintaining their fire protection system and devices in proper operating condition. The installing contractor or sprinkler manufacturer should be contacted with any questions.

Model/Sprinkler Identification Numbers

TY3331 - Horizontal
TY3431 - Vertical

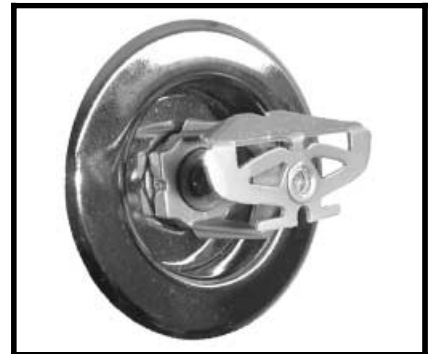

Technical Data

Approvals

UL and C-UL Listed.
FM, LPCB, and NYC Approved.
(Refer to Table A for complete approval information including corrosion resistant status.)

Maximum Working Pressure

Refer to Table B.

Discharge Coefficient

$K = 5.6 \text{ GPM/psi}^{1/2}$ (80,6 LPM/bar^{1/2})

Temperature Ratings

Refer to Table A.

Finishes

Sprinkler: Refer to Table A.
Recessed Escutcheon: White Coated, Chrome Plated, or Brass Plated.

IMPORTANT

Always refer to Technical Data Sheet TFP700 for the "INSTALLER WARNING" that provides cautions with respect to handling and installation of sprinkler systems and components. Improper handling and installation can permanently damage a sprinkler system or its components and cause the sprinkler to fail to operate in a fire situation or cause it to operate prematurely.

K	TYPE	TEMP.	BULB LIQUID	SPRINKLER FINISH (See Note 11)			
				NATURAL BRASS	CHROME PLATED	WHITE*** POLYESTER	LEAD COATED
5.6 1/2" NPT	HORIZ. SIDEWALL (TY3331)	135°F/57°C	Orange	1, 2, 3, 4, 9, 10		1, 2, 3, 9	1, 2, 3, 9
		155°F/68°C	Red				
		175°F/79°C	Yellow				
		200°F/93°C	Green				
		286°F/141°C	Blue				
	RECESSED HORIZ. SIDEWALL (TY3331)* Figure 3	135°F/57°C	Orange	1, 2, 4, 9, 10		1, 2, 9	N/A
		155°F/68°C	Red				
		175°F/79°C	Yellow				
		200°F/93°C	Green				
	RECESSED HORIZ. SIDEWALL (TY3331)** Figure 4	135°F/57°C	Orange	1, 2, 3, 4, 9			N/A
		155°F/68°C	Red				
		175°F/79°C	Yellow				
200°F/93°C		Green					
5.6 1/2" NPT	VERTICAL SIDEWALL (TY3431) Installed Pendent or Upright	135°F/57°C	Orange	5, 6, 7, 8, 9			5, 6, 7, 9
		155°F/68°C	Red				
		175°F/79°C	Yellow				
		200°F/93°C	Green				
		286°F/141°C	Blue				

NOTES:

- Listed by Underwriters Laboratories, Inc. (UL) as Quick Response Sprinklers for use in Light and Ordinary Hazard Occupancies at a 4 to 12 inch (100 to 300 mm) top of deflector to ceiling distance.
 - Listed by Underwriters Laboratories Inc. for use in Canada (C-UL) as Quick Response Sprinklers for use in Light and Ordinary Hazard Occupancies at a 4 to 12 inch (100 to 300 mm) top of deflector to ceiling distance.
 - Approved by Factory Mutual Research Corporation (FM) as Quick Response Sprinklers for use in Light Hazard Occupancies at a 4 to 12 inch (100 to 300 mm) top of deflector to ceiling distance.
 - Approved by the Loss Prevention Certification Board (LPCB Ref. No. 007a/04) at a 4 to 6 inch (100 to 150 mm) top of deflector to ceiling distance. The LPC does not rate the thermal sensitivity of horizontal sidewall sprinklers.
 - Listed by Underwriters Laboratories, Inc. as Quick Response Sprinklers for use in Light and Ordinary Hazard Occupancies.
 - Listed by Underwriters Laboratories for use in Canada (C-UL) as Quick Response Sprinklers for use in Light and Ordinary Hazard Occupancies.
 - Approved by Factory Mutual Research Corporation (FM) as Quick Response Sprinklers for use in Light Hazard Occupancies.
 - Approved by the Loss Prevention Certification Board (LPCB Ref. No. 094a/06 & 007a/04) as Quick Response Sprinklers.
 - Approved by the City of New York under MEA 354-01-E.
 - Approved by the Loss Prevention Certification Board (LPCB Ref. No. 094a/06) at a 4 to 6 inch (100 to 150 mm) top of deflector to ceiling distance. The LPC does not rate the thermal sensitivity of horizontal sidewall sprinklers.
 - Where Polyester Coated and Lead Coated Sprinklers are noted to be UL and C-UL Listed, the sprinklers are UL and C-UL Listed as Corrosion Resistant Sprinklers. Where Lead Coated Sprinklers are noted to be FM Approved, the sprinklers are FM Approved as Corrosion Resistant Sprinklers.
- * Installed with Style 10 (1/2" NPT) 3/4" Total Adjustment Recessed Escutcheon.
 ** Installed with Style 20 (1/2" NPT) 1/2" Total Adjustment Recessed Escutcheon.
 *** Frame and deflector only. Listings and approvals apply to color (Special Order).

**TABLE A
LABORATORY LISTINGS AND APPROVALS**

Physical Characteristics

Frame Bronze
 Button Brass/Copper
 Sealing Assembly
 Beryllium Nickel w/Teflon†
 Bulb Glass
 Compression Screw Bronze
 HSW Deflector Bronze
 VSW Deflector Copper

Patents

U.S.A. 5,810,263

Operation

The glass Bulb contains a fluid which expands when exposed to heat. When the rated temperature is reached, the fluid expands sufficiently to shatter the glass Bulb, allowing the sprinkler to activate and water to flow.

K	TYPE	SPRINKLER FINISH			
		NATURAL BRASS	CHROME PLATED	WHITE POLYESTER	LEAD COATED
5.6 1/2" NPT	HORIZONTAL SIDEWALL (TY3331)	250 PSI (17,2 BAR) OR 175 PSI (12,1 BAR)			175 PSI (12,1 BAR)
	RECESSED HORIZ. SIDEWALL (TY3331)	(SEE NOTE 1)			N/A
	VERTICAL SIDEWALL (TY3431)	175 PSI (12,1 BAR)			

NOTES:

1. The maximum working pressure of 250 psi (17,2 bar) only applies to the Listing by Underwriters Laboratories, Inc. (UL); the Listing by Underwriters Laboratories, Inc. for use in Canada (C-UL); and, the Approval by the City of New York.

TABLE B, MAXIMUM WORKING PRESSURE

Design Criteria

The Series TY-FRB Horizontal and Vertical Sidewall Sprinklers are intended for fire protection systems designed in accordance with the standard installation rules recognized by the applicable Listing or Approval agency (e.g., UL Listing is based on the requirements of NFPA 13, and FM Approval is based on the requirements of FM's Loss Prevention Data Sheets). Only the Style 10 or 20 Recessed Escutcheon, as applicable, is to be used for recessed horizontal installations.

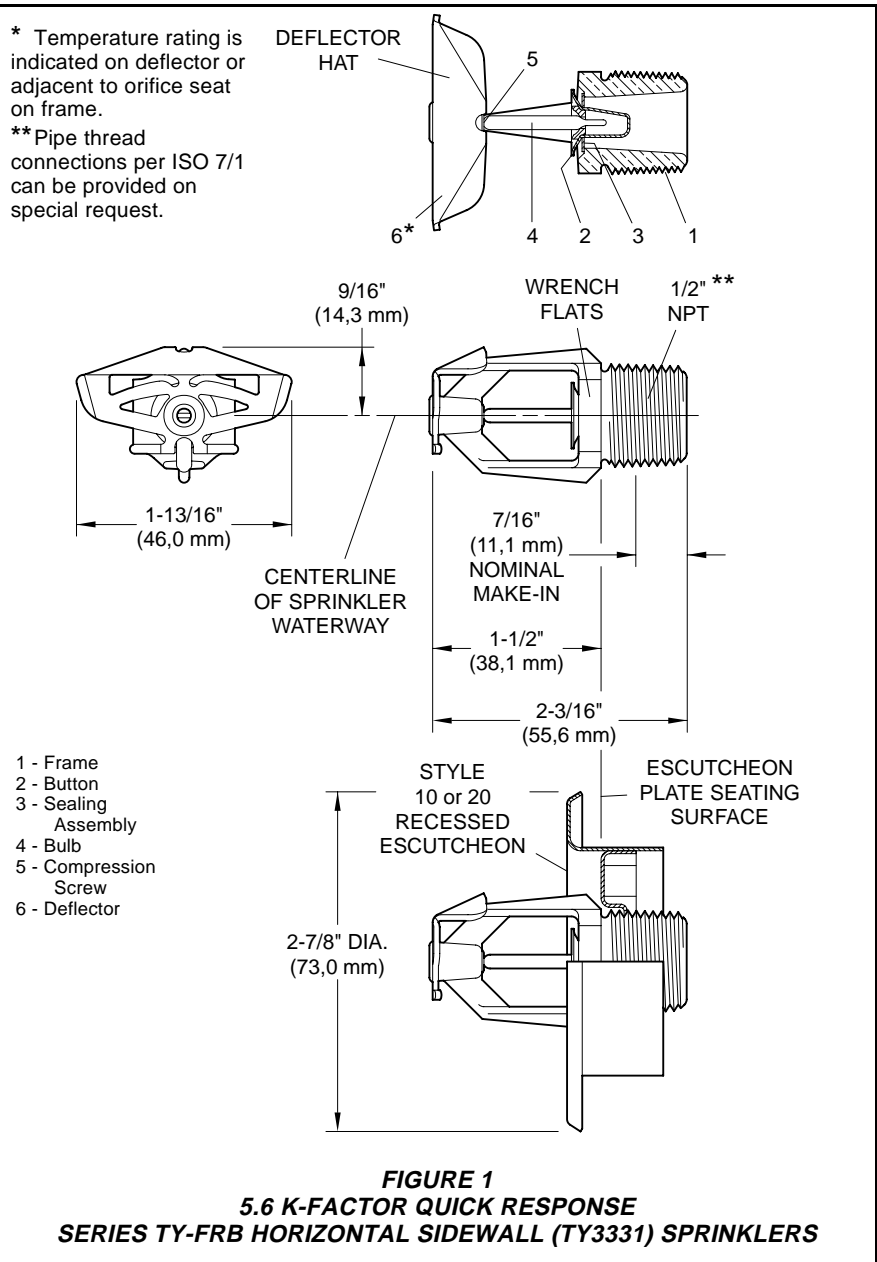

Installation

The Series TY-FRB Sprinklers must be installed in accordance with the following instructions:

NOTES

Do not install any bulb type sprinkler if the bulb is cracked or there is a loss of liquid from the bulb. With the sprinkler held horizontally, a small air bubble should be present. The diameter of the air bubble is approximately 1/16 inch (1,6 mm) for the 135°F/57°C to 3/32 inch (2,4 mm) for the 286°F/141°C temperature ratings.

A leak tight 1/2 inch NPT sprinkler joint should be obtained with a torque of 7 to 14 ft.lbs. (9,5 to 19,0 Nm). A maximum of 21 ft. lbs. (28,5 Nm) of torque may be used to install sprinklers with 1/2 NPT connections. Higher levels of torque may distort the sprinkler and cause leakage or impairment of the sprinkler.

Do not attempt to make-up for insufficient adjustment in the escutcheon plate by under- or over-tightening the sprinkler. Readjust the position of the sprinkler fitting to suit.

The **Series TY-FRB Horizontal and Vertical Sidewall Sprinklers** must be installed in accordance with the following instructions.

Step 1. Horizontal sidewall sprinklers are to be installed in the horizontal position with their centerline of waterway perpendicular to the back wall and parallel to the ceiling. The word "TOP" on the Deflector is to face towards the ceiling.

Vertical sidewall sprinklers are to be installed in the pendent or upright position with the arrow on the Deflector pointing away from the wall.

Step 2. With pipe thread sealant applied to the pipe threads, hand tighten the sprinkler into the sprinkler fitting.

Step 3. Tighten the sprinkler into the sprinkler fitting using only the W-Type 6 Sprinkler Wrench (Ref. Figure 5), With reference to Figure 1 or 2, the W-Type 6 Sprinkler Wrench is to be applied to the wrench flats.

The **Series TY-FRB Recessed Horizontal Sidewall Sprinklers** must be installed in accordance with the following instructions.

Step A. Recessed horizontal sidewall sprinklers are to be installed in the horizontal position with their centerline of waterway perpendicular to the back wall and parallel to the ceiling. The word "TOP" on the Deflector is to face towards the ceiling.

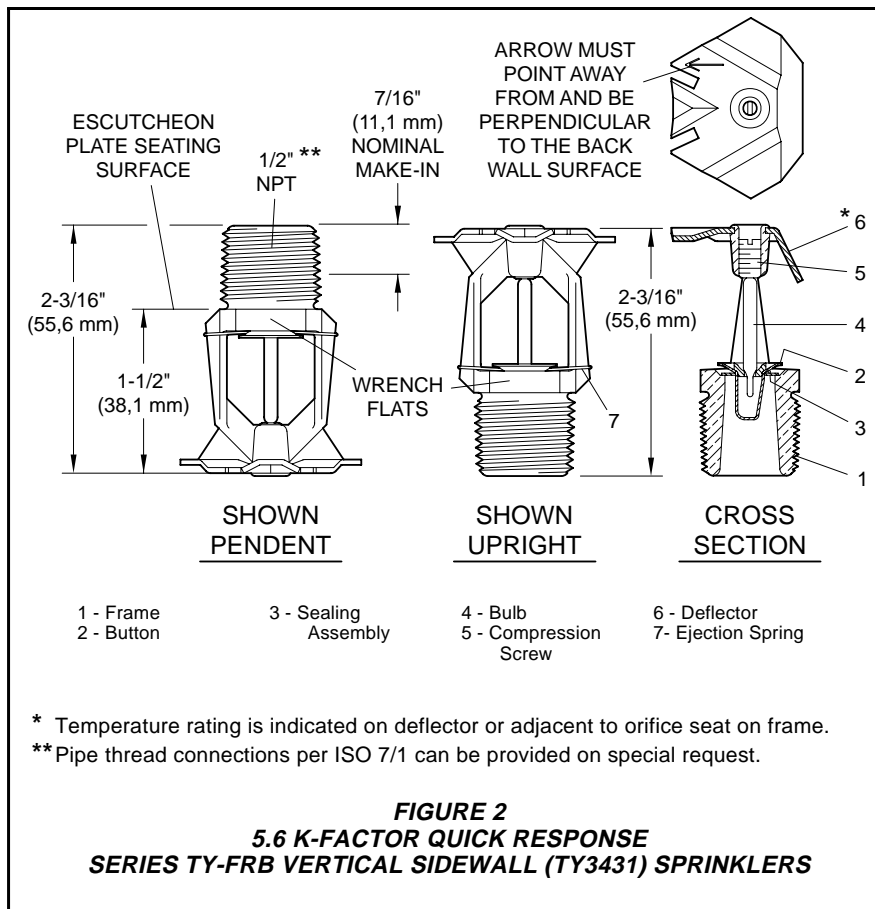

Step B. After installing the Style 10 or 20 Mounting Plate over the sprinkler threads, hand tighten the sprinkler into the sprinkler fitting.

Step C. Tighten the sprinkler into the sprinkler fitting using only the W-Type 7 Recessed Sprinkler Wrench (Ref. Figure 6). With reference to Figure 1, the W-Type 7 Recessed Sprinkler Wrench is to be applied to the sprinkler wrench flats.

Step D. After the ceiling has been installed or the finish coat has been applied, slide on the Style 10 or 20 Closure over the Series TY-FRB Sprinkler and push the Closure over the Mounting Plate until its flange comes in contact with the ceiling

Care and Maintenance

The Series TY-BFR Sprinklers must be maintained and serviced in accordance with the following instructions:

NOTES

Before closing a fire protection system main control valve for maintenance work on the fire protection system that it controls, permission to shut down the affected fire protection system must be obtained from the proper authorities and all personnel who may be affected by this action must be notified.

The owner must assure that the sprinklers are not used for hanging of any objects; otherwise, non-operation in the event of a fire or inadvertent operation may result.

Absence of an escutcheon, which is used to cover a clearance hole, may delay the time to sprinkler operation in a fire situation.

Sprinklers that are found to be leaking or exhibiting visible signs of corrosion

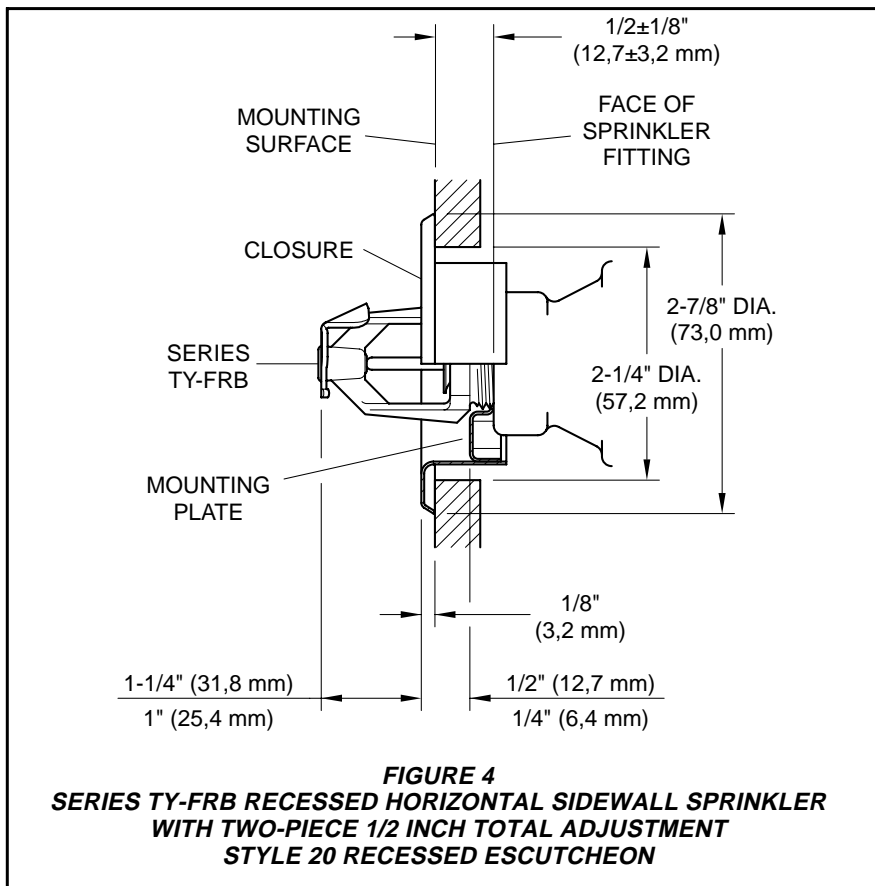
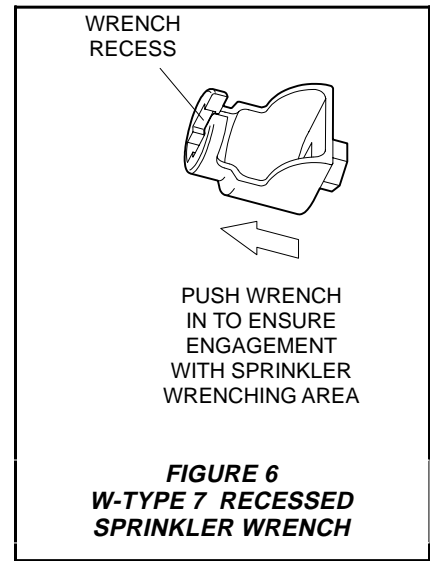
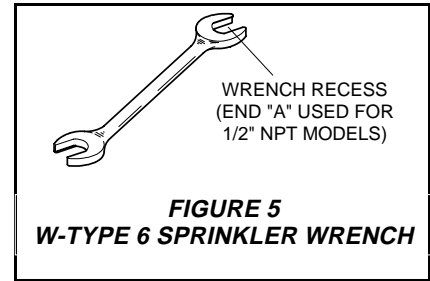
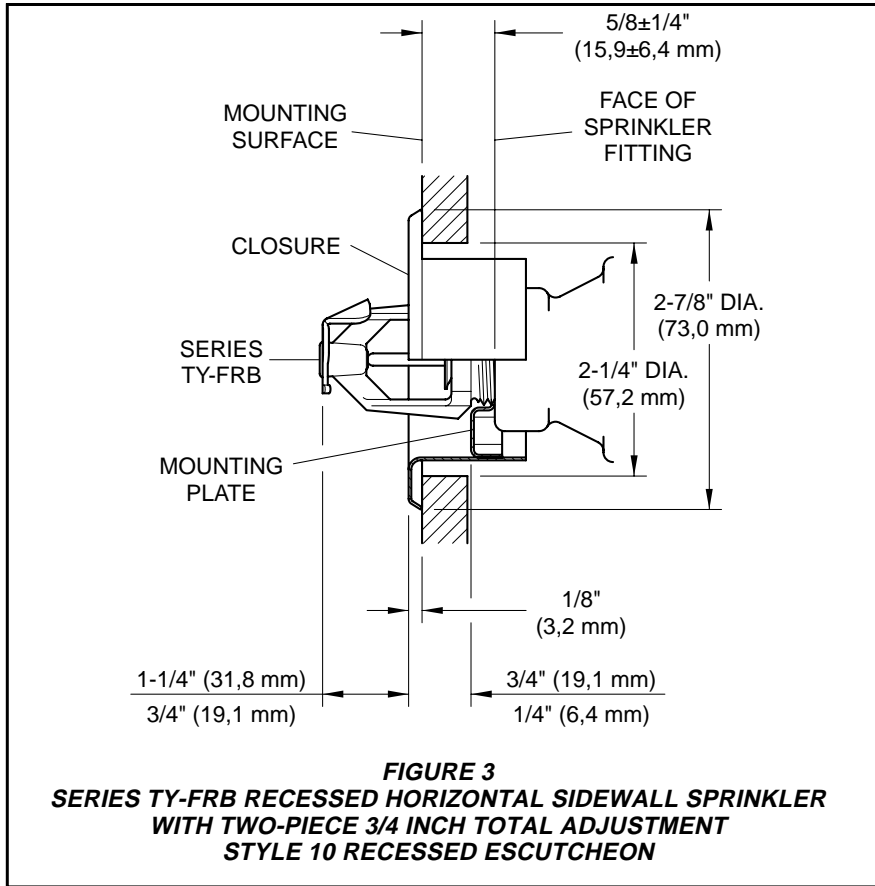

must be replaced.

Automatic sprinklers must never be painted, plated, coated or otherwise altered after leaving the factory. Modified sprinklers must be replaced. Sprinklers that have been exposed to corrosive products of combustion, but have not operated, should be replaced if they cannot be completely cleaned by wiping the sprinkler with a cloth or by brushing it with a soft bristle brush.

Care must be exercised to avoid damage to the sprinklers - before, during, and after installation. Sprinklers damaged by dropping, striking, wrench twist/slippage, or the like, must be replaced. Also, replace any sprinkler that has a cracked bulb or that has lost liquid from its bulb. (Ref. Installation Section).

Frequent visual inspections are recommended to be initially performed for corrosion resistant coated sprinklers, after the installation has been completed, to verify the integrity of the corrosion resistant coating. Thereafter, annual inspections per NFPA 25 should suffice; however, instead of inspecting from the floor level, a random sampling of close-up visual inspections should be made, so as to better determine the exact sprinkler condition and the long term integrity of the

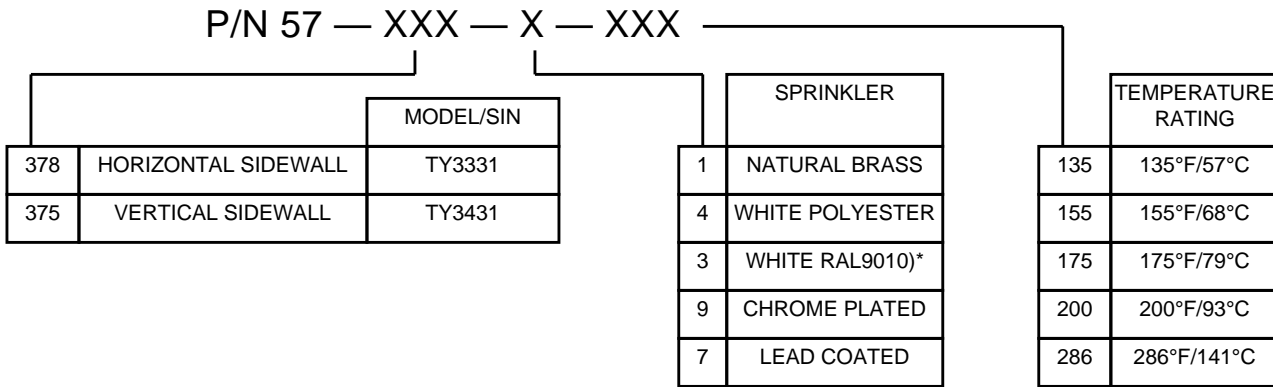

TABLE C
PART NUMBER SELECTION
SERIES TY-FRB HORIZONTAL AND VERTICAL SIDEWALL SPRINKLERS

* Eastern Hemisphere sales only.

corrosion resistant coating, as it may be affected by the corrosive conditions present.

The owner is responsible for the inspection, testing, and maintenance of their fire protection system and devices in compliance with this document, as well as with the applicable standards of the National Fire Protection Association (e.g., NFPA 25), in addition to the standards of any other authorities having jurisdiction. The installing contractor or sprinkler manufacturer should be contacted relative to any questions.

It is recommended that automatic sprinkler systems be inspected, tested, and maintained by a qualified Inspection Service in accordance with local requirements and/or national codes.

Limited Warranty

Products manufactured by Tyco Fire & Building Products (TFBP) are warranted solely to the original Buyer for ten (10) years against defects in material and workmanship when paid for and properly installed and maintained under normal use and service. This warranty will expire ten (10) years from date of shipment by TFBP. No warranty is given for products or components manufactured by companies not affiliated by ownership with TFBP or for products and components which have been subject to misuse, improper installation, corrosion, or which have not been installed, maintained, modified or repaired in accordance with applicable Standards of the National Fire Protection Association, and/or the

standards of any other Authorities Having Jurisdiction. Materials found by TFBP to be defective shall be either repaired or replaced, at TFBP's sole option. TFBP neither assumes, nor authorizes any person to assume for it, any other obligation in connection with the sale of products or parts of products. TFBP shall not be responsible for sprinkler system design errors or inaccurate or incomplete information supplied by Buyer or Buyer's representatives.

In no event shall TFBP be liable, in contract, tort, strict liability or under any other legal theory, for incidental, indirect, special or consequential damages, including but not limited to labor charges, regardless of whether TFBP was informed about the possibility of such damages, and in no event shall TFBP's liability exceed an amount equal to the sales price.

The foregoing warranty is made in lieu of any and all other warranties, express or implied, including warranties of merchantability and fitness for a particular purpose.

This limited warranty sets forth the exclusive remedy for claims based on failure of or defect in products, materials or components, whether the claim is made in contract, tort, strict liability or any other legal theory.

This warranty will apply to the full extent permitted by law. The invalidity, in whole or part, of any portion of this warranty will not affect the remainder.

Ordering Procedure

When placing an order, indicate the full product name. Refer to the Price List for complete listing of Part Numbers.

Contact your local distributor for availability.

Sprinkler Assemblies with NPT Thread Connections:

Specify: (Specify Model/SIN), Quick Response, (specify K-factor), (specify temperature rating), Series TY-FRB (specify Horizontal Sidewall or Vertical Sidewall) Sprinkler with (specify type of finish or coating), P/N (specify from Table C).

Recessed Escutcheon:

Specify: Style (10 or 20) Recessed Escutcheon with (specify*) finish, P/N (specify*).

* Refer to Technical Data Sheet TFP770.

Sprinkler Wrench:

Specify: W-Type 6 Sprinkler Wrench, P/N 56-000-6-387.

Specify: W-Type 7 Sprinkler Wrench, P/N 56-850-4-001.