

Reliable®

Model E3 High Pressure Alarm Check Valve 4" (100mm), 6" (150mm), 165 mm & 8" (200mm)

Features

1. 300 psi (20,7 bar) ratings. Factory tested hydrostatically to 600 psi (41,4 bar).
2. Grooved seat design ensures positive water flow alarm operation.
3. Precision retard chamber minimizes false alarms under variable pressure conditions.
4. External by-pass minimizes false alarms under all supply pressure conditions.
5. Grooved inlet and outlet connections. Less weight than flange valves.
6. Vertical and horizontal trims available.
7. Three compact galvanized trim styles available:
 - Individual part trim
 - Segmentally assembled trim
 - Factory trimmed valve
8. TestANDrain® valve with pressure relief, optional:
 - Exercises the clapper with alarm test.
 - Functions like the Inspector's Test Port with greater convenience.



Description

The Reliable Model E3 Alarm Valve activates the water flow alarm device in wet pipe sprinklers systems. The design allows for installation under both variable and constant supply pressure conditions. When water flows in the sprinkler system due to the operation of one or more automatic fire sprinklers, the alarm valve opens, allowing continuous flow of water into the system and transmittal of water pressure to electrical and/or mechanical water flow alarm devices.

Approvals & Listings

1. Listed by Underwriters Laboratories, Inc. and Certified by UL for Canada (cULus).
2. Approved by FM Research (FM).
 - When used with the Model E3 trim sets.
 - Optional TestANDrain® Valve is not FM Approved.
3. Scientific Services Laboratory (SSL, Australia). 100mm, 165mm & 200mm.
4. NYC MEA 258-93-E
5. Conforms to EN 12259-2 metric sizes only (CE).

Ordering Information – Specify:

- Valve size – 4" (100mm) or 6" (150mm), or 165mm or 8" (200mm).
- Type of trim – Constant Pressure or Variable Pressure.
- Style of trim – Individual parts trim, segmentally assembled trim, or factory trimmed valve.

Operation

Variable Pressure

The Reliable Model E3 High Pressure Alarm Valve in its closed and open positions is shown in Figures 1 and 2. The closed position is maintained as long as the water pressure in the sprinkler system piping above the alarm valve is greater than, or equal to, the supply pressure. A flow of water in the system piping, resulting from the discharge through one or more fused automatic sprinklers, causes the clapper to rise off its grooved seat and permits water from the supply to enter the system for distribution on the fire.

Water now flows through the uncovered groove and alarm line into the retard chamber. Once the retard chamber is filled the water flow activates the mechanical and electrical alarms (Figs. 3 & 4).

Virtually all sprinkler system piping contains confined air. If a water hammer or pressure surge occurs in the supply line, the increased pressure will compress the confined air and cause the alarm valve clapper to lift intermittently which may result in false alarms. The Reliable Model E3 Alarm Valve minimizes false alarms under these conditions by two features:

- The by-pass connection with check valve (Figs. 3 & 4) allows pressure surges from the supply to by-pass the alarm valve clapper. An excess system pressure is thus created which steadies the clapper. Should a heavy surge unseat the clapper and permit water to flow into the alarm line, the retarding chamber then comes into action.
- Two Drain Orifice restrictions on the supply side of the Retard Chamber allow intermittent flow to be drained before the Chamber fills and activates the alarms.

Constant Pressure

The operation of the Model E3 Alarm Valve in installations where the water pressure is constant is the same as described above, with this exception: The retard chamber is not required and water passing through the groove in the alarm valve seat flows directly to activate the mechanical and electrical alarms.

Model E3 High Pressure Alarm Valve (Figs. 1&2)

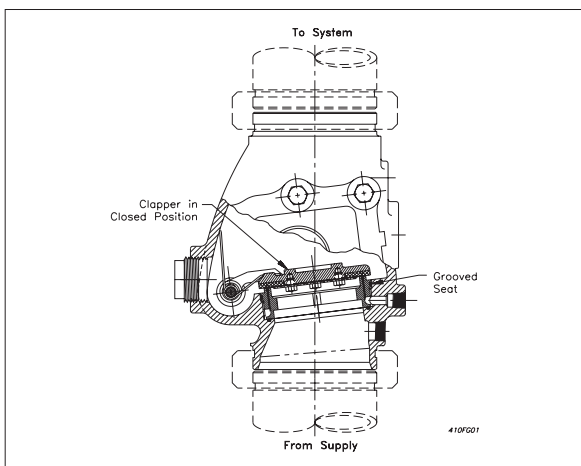

Fig. 1 Closed Position

Valve Description

- Rated working pressure: 300 (20,7 bar).
- Factory hydrostatic test pressure: 600 psi (41,4 bar).
- End and trim connections:
 - Threaded openings per ANSI B 2.1 or ISO 7/1 R.
 - Grooves per ANSI/AWWA C606.
- Color: Black.
Red (E3A*)
Red (Metric)

Groove Dimensions										
Valve Size	Outlet Dia.		Groove Dia.		Groove Width		Face To Groove Dim.		Valve Type	
	in.	mm	in.	mm	in.	mm	in.	mm		
4	100	4.500	114.0	4.334	110.1	3/8	9.5	5/8	16	E3 & E3A*
6	150	6.625	168.0	6.455	164.0	3/8	9.5	5/8	16	E3
6	165	6.500	165.0	6.330	160.8	3/8	9.5	5/8	16	E3A*
8	200	8.625	219	8.441	214	7/16	11	3/4	19	E3 & E3A*

* "A" designates valves made for Australia

Model E3 Trim Description

The basic trims for the Reliable Model E3 High Pressure Alarm Valve (Figs. 3 & 4), are arranged for rapid, easy and compact attachment, and serve as connection points to Reliable alarm and other devices. They also act as a means for testing the operation of the alarm devices without causing the system to operate. The Model E3 high pressure alarm valves are available in two trims and may be installed in the vertical or horizontal position in the main supply to the wet pipe system:

- Constant Pressure Closed Drain** – Retard chamber not required. This trim set is used where water supply pressure does not vary such as a gravity tank. The mechanical sprinkler alarm line automatically drains to the 2" (50mm) main drain line.
- Variable Pressure Closed Retard Chamber Drain** – Retard chamber required. This trim set is used where water supply pressures vary. The retard chamber and mechanical sprinkler alarm line are drained through a closed, checked connection to the 2" (50mm) main drain line. Only one drain connection is required.

Note:

- The trim set permits both vertical and horizontal installation.
- A TestANDrain® valve segment is optional, to be purchased separately, as a replacement to the valve (Figs. 3 & 4).

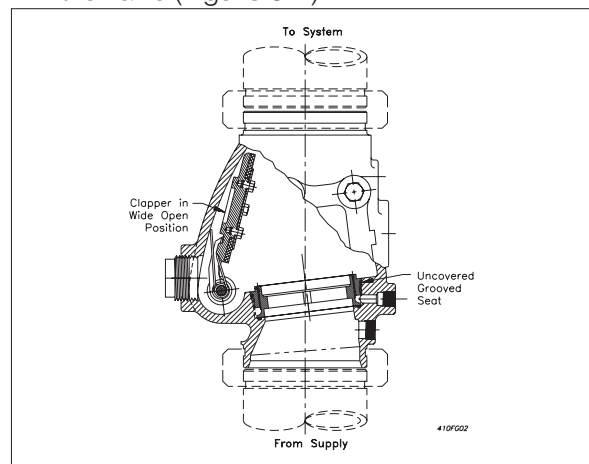

Fig. 2 Open Position

E-3 Vertical and Horizontal Trims:

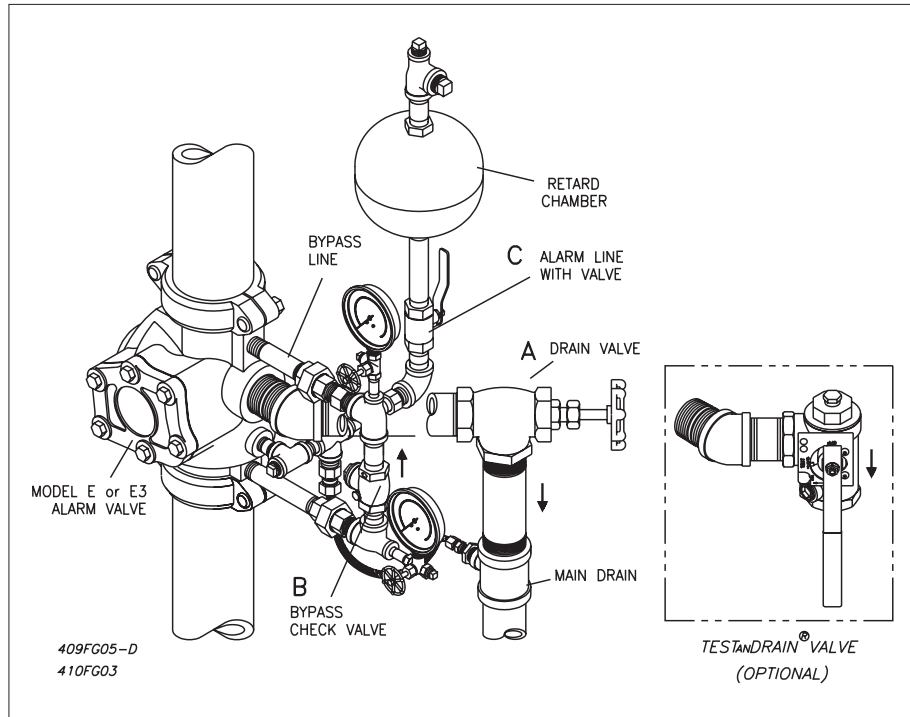

Fig. 3 E3 Vertical Trim

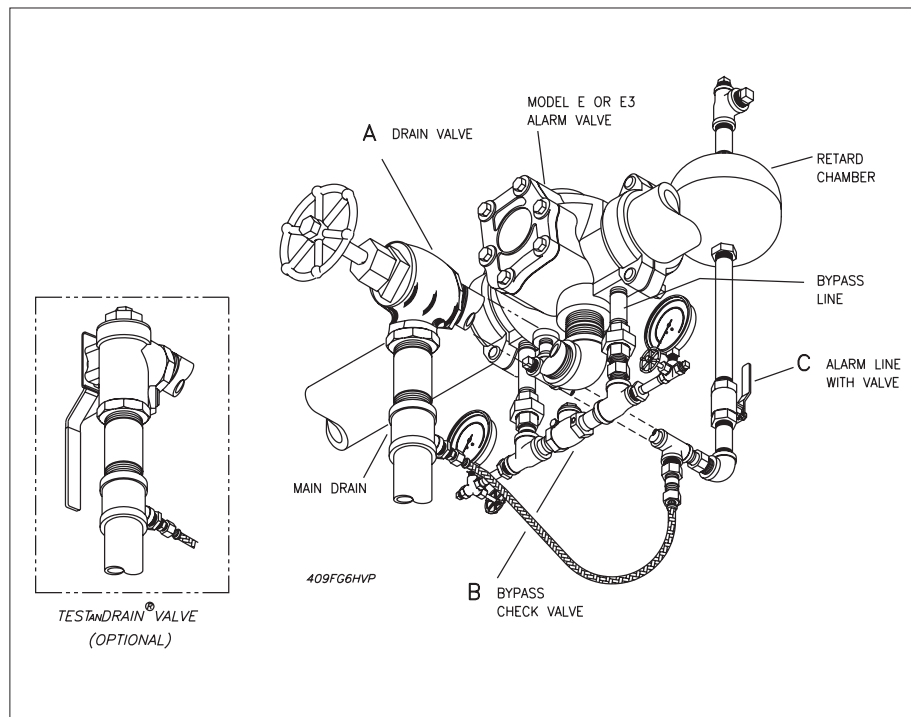

Fig. 4 E3 Horizontal Trim

Model E3 Vertical & Horizontal Trim Illustrations

Installation Dimensions in Inches (mm)

Valve	A	B	C	D	E	F	G	H	I	J	K	L	M
4" (100mm)	7" (178)	10½" (267)	15" (381)	6" (152)	16¾" (426)	15" (381)	3½" (89)	5¾" (146)	12" (305)	4½" (114)	6½" (165)	10" (254)	8¼" (210)
6" (150mm) (165mm)	7⅝" (194)	11½" (292)	16" (406)	7" (178)	15¼" (387)	16½" (419)	4¼" (108)	7" (108)	12" (305)	4½" (114)	6½" (165)	10" (254)	6¾" (172)
8" (200mm)	7⅝" (194)	11½" (292)	16" (406)	7" (178)	15¼" (387)	16½" (419)	4¼" (108)	7" (108)	12" (305)	4½" (114)	6½" (165)	10" (254)	6¾" (172)

Installation must be made with 300 psi (20,7 bar) minimum rated grooved couplings, such as the Star® Fittings Model C-2 LW. To mate with ANSI Class 250 or Class 300 Flanges, use listed grooved flanged adapters having appropriate pressure rating.

Variable Pressure,
Vertical Trim — Top View

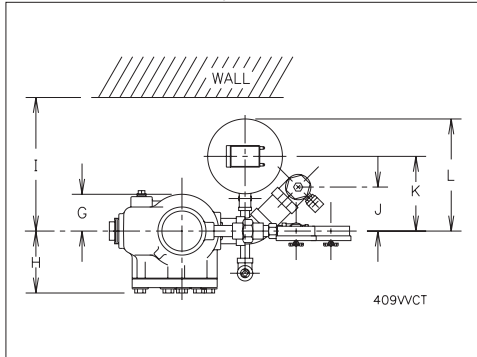

Variable Pressure,
Horizontal Trim — Top View

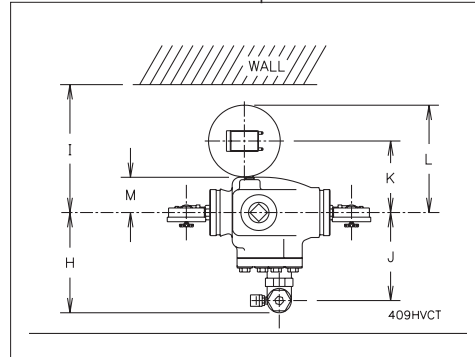

Variable Pressure,
Vertical Trim — Front Elevation

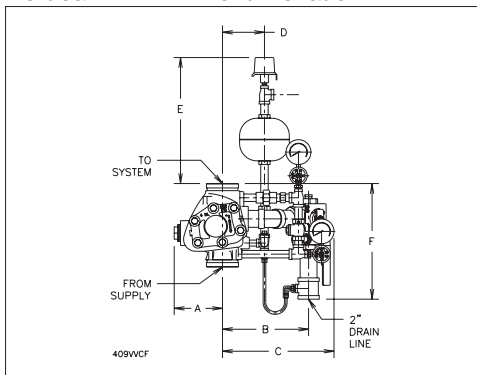

Variable Pressure,
Horizontal Trim — Front Elevation

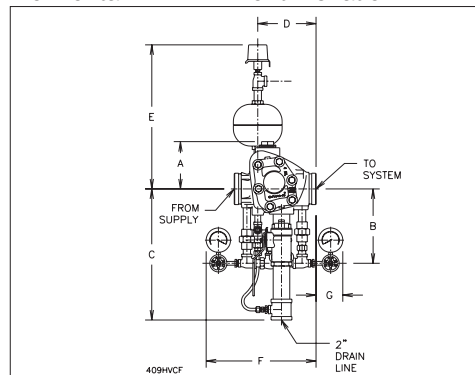

Constant Pressure,
Vertical Trim — Front Elevation

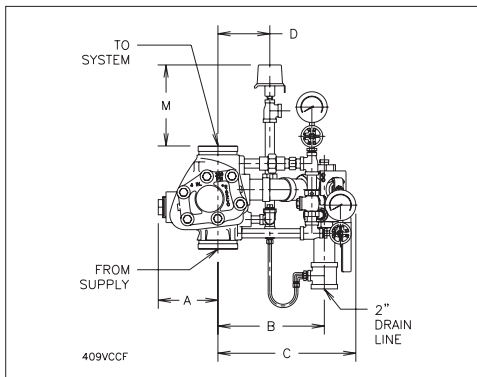

Constant Pressure,
Horizontal Trim — Front Elevation

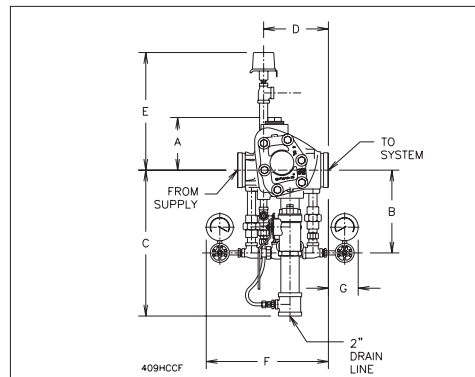

The equipment presented in this bulletin is to be installed in accordance with the latest published Standards of the National Fire Protection Association, Factory Mutual Research Corporation, or other similar organizations and also with the provisions of governmental codes or ordinances whenever applicable.

Products manufactured and distributed by Reliable have been protecting life and property for over 80 years, and are installed and serviced by the most highly qualified and reputable sprinkler contractors located throughout the United States, Canada and foreign countries.

Manufactured by:



The Reliable Automatic Sprinkler Co., Inc.

800.431.1588
800.848.6051
914.829.2042
www.reliablesprinkler.com

Sales Offices
Sales Fax
Corporate Offices
Internet Address



Recycled
Paper

Revision lines indicate updated or new data.
E.G. Printed in USA 10/06 P/N 9999970179