

Reliable®

Model E Alarm Check Valve

Instructions for Installation, Operation, Care and Maintenance

2½" — 3" Size With Model E1 Trim

Listed by Underwriters Laboratories, Inc. Approved by Factory Mutual Research Corporation, and other fire insurance and governmental agencies in the United States and foreign countries.

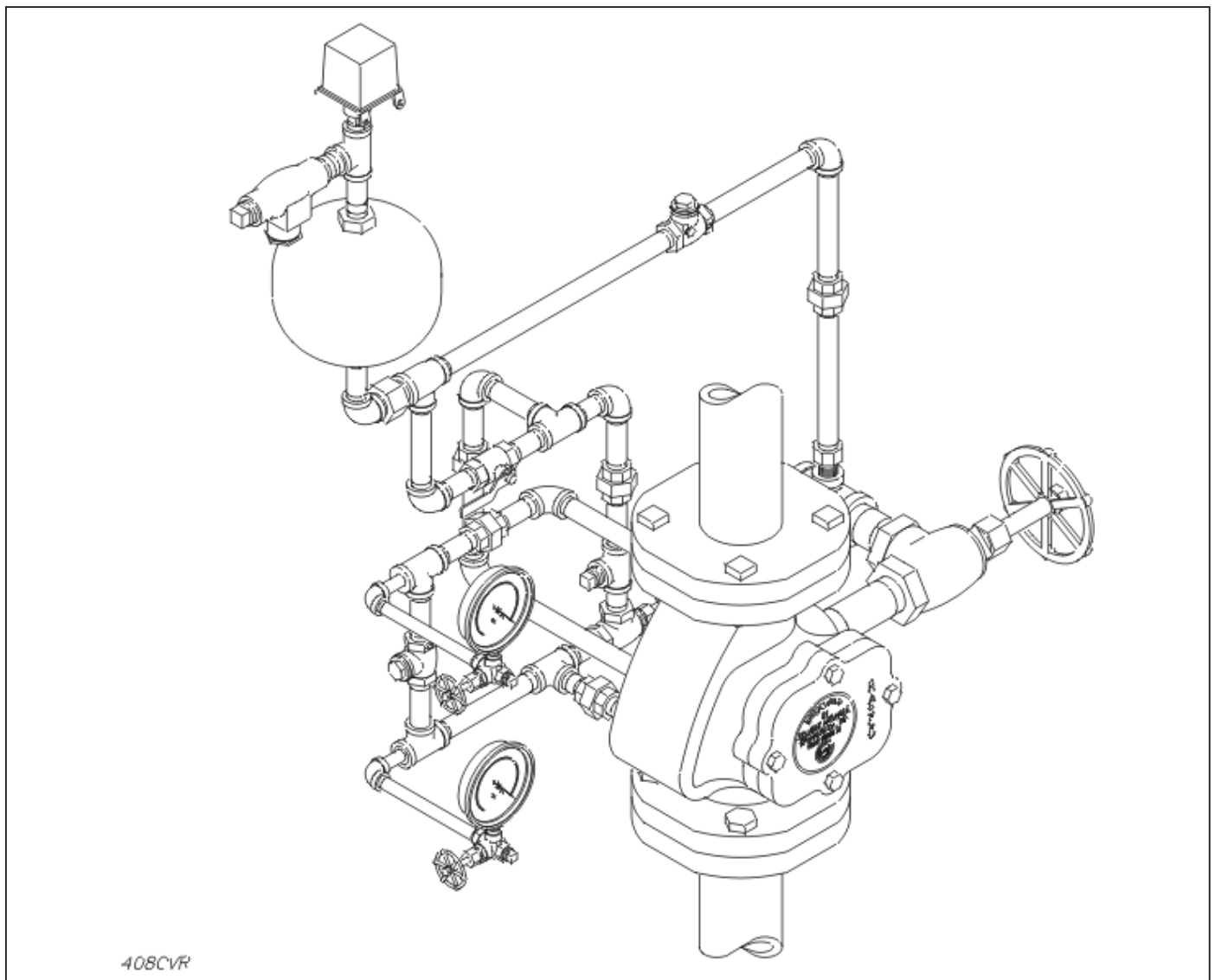

408CVR

General

Reliable Model E Alarm Valves are installed in either the vertical or horizontal position in the main supply to the wet pipe system. Variable pressure water supply requires the use of either of two Model E-1 variable pressure trim sets and a Reliable Model E-1 Retarding Chamber. Constant pressure water supply requires the use of a Model E-1 constant pressure trim set only. Model E Alarm Valves are shipped with the designated Model E-1 trim set, i.e., variable/open drain, variable/closed drain or constant pressure.

Valve Description

1. Rated working pressure 175 psi (12, 1 bar).
2. Factory hydrostatic pressure 350 psi (24, 2 bar).
3. End and trim connections—Three valve connection styles are available:
 - a) U.S. Standard Flanged Inlet and Outlet:
 - Flanges mate with ANSI B 16.1 (125 lb.) Flange.

U.S. Flange Dimensions in Inches					
Valve Size	Bolt Circle Diameter	Bolt Hole Diameter	Square Flange Dimension	Flange Thickness	No. Bolts
2½"	5½"	¾"	6⅞"	¾"	4
3"	6"	¾"	6⅞"	¾"	4

- Threaded openings per ANSI B 2.1.
 - Reliable's standard trim sets are compatible with U.S. Flanged Valves.
 - Color—Black.
- b) U.S. Standard Flanged Inlet and Grooved Outlet (Figure 1):
 - Inlet flange mates with ANSI B 16.1 (125 lb.) Flange.

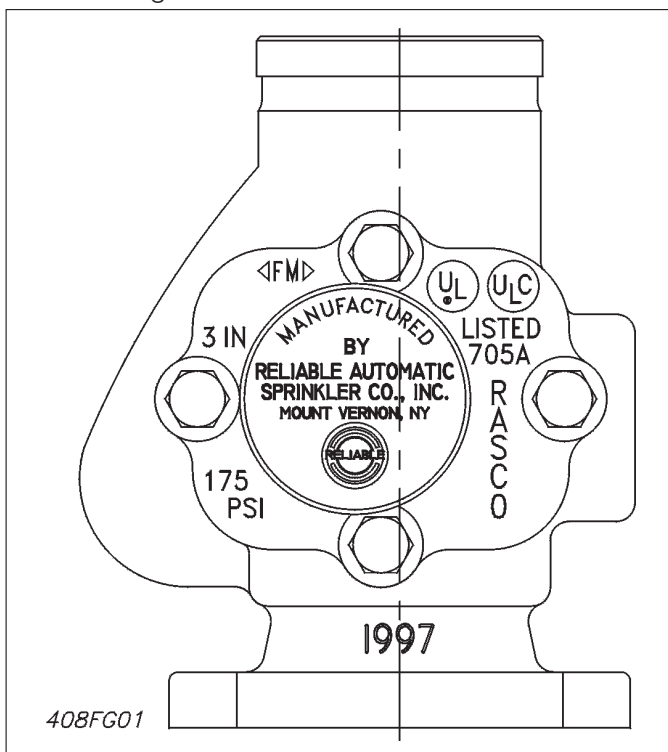

U.S. Groove Dimensions in Inches				
Valve Size	Outlet Diameter	Groove Diameter	Groove Width	Outlet Face to Groove
3"	3.500	3.344	5/16"	5/8"

- Outlet groove per ANSI/AWWA C606.
 - Threaded openings per ANSI B 2.1.
 - Reliable's standard trim sets are compatible with U.S. Flanged and Grooved Valves.
 - Color—Black.
- c) Metric Flanged Inlet and Outlet:
 - Flanges mate with DIN 2500 8.66, NF-E-29-282 and BS 4504 NP 16 Flanges.

Metric Flange Dimensions in Millimeters					
Valve Size	Bolt Circle Diameter	Bolt Hole Diameter	Square Flange Dimension	Flange Thickness	No. Bolts
65mm	145.	18.23	155.57	19.05	4

- Threaded openings ISO 7/1-Rp.
 - Reliable's standard trim sets may be used with metric valves providing trim is assembled carefully and extra thread sealant is applied to connections between valves and trim.
 - Color—Red.
4. Face to Face Dimension:
 - 2½", 3" & 65mm - 9⅜" (233mm).
 5. Friction Loss—Expressed in Equivalent Length of Pipe, Based on Hazen-Williams formula with C=120.

Size	Equiv. Length
2½"	7.7' (2.35m)
3"	21.5' (6.55m)

Trim Description

The basic trimmings for the Reliable Model E Alarm Valve (Figure 2) are arranged for rapid, easy and compact attachment, and serve as connection points to Reliable alarm and other devices. They also act as a means for testing the operation of the alarm devices without causing the system to operate.

Three basic Model E-1 trim sets are available for use with the Model E Alarm Valve:

- **Constant Pressure** — Retard is not required. This trim set is used where water supply pressure does not vary. An open drip cup is provided to drain the mechanical sprinkler alarm line. This drain connection should be piped separately from the 1¼" main drain.
- **Variable Pressure with Open Retard Drain**— Retard is required. This trim is used where water supply pressures vary. An open drip cup is provided to drain the retard chamber and the mechanical sprinkler

alarm line. This drain connection should be piped separately from the 1¼" main drain.

- **Variable Pressure with Closed Retard Drain**—Retard is required.

This trim set is used where water supply pressures vary. The retard chamber and the mechanical sprinkler alarm line are drained through a closed, checked connection to the 1¼" drain line. Only one drain connection is required.

Each basic trim set permits either horizontal or vertical installation.

For all basic trim sets, the drain line should be more than 2 feet below the drip cup or retard chamber inlet.

Alarm valves are listed and approved by Underwriters Laboratories, Inc. and Factory Mutual Research Corp. only when used with the valve manufacturer's trim sets.

Trim kits are available galvanized, in three trim styles:

- Individual Part Trim.
- Pre-Assembled trim.
- Factory Trimmed valve.

Pressure Relief Trim Kits

A pressure relief trim kit is required with a gridded wet pipe systems.

Pressure relief trim kits are to be installed in Model E-1 variable pressure trim sets, and are available in three versions illustrated on page 12:

- 175 PSI, FM Approved (Adjustable Relief Valve).

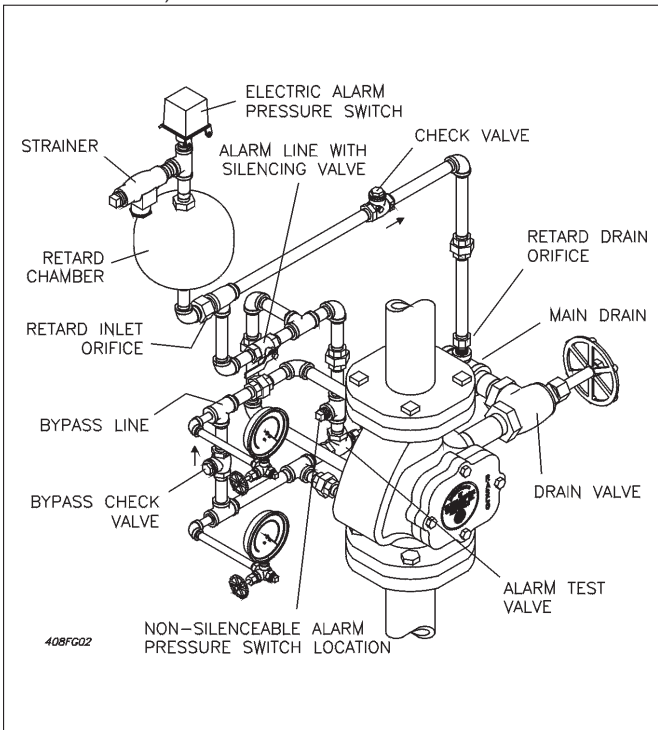

Figure 2—Model E 3" Flange Inlet and Outlet Alarm Valve—Variable Pressure Closed Drain Trim

- 185 PSI, FM Approved (Adjustable Relief Valve).
- 175 PSI, UL Listed (Fixed Relief Valve).

All versions include all parts necessary to install in either open or closed retard drain trim kits.

Assembly of Model E-1 Trim

Variable Pressure — Closed Retard Drain Vertical Installation (Figure 3)

The following description refers to the trim as shown in this bulletin. The trim may differ from this bulletin. Refer to the drawing/caution sheet supplied with each trim set.

1. Install Nipple (37) in bottom ½" tapped body opening (supply port of bypass line) and connect remaining parts in proper order to Union (11).

Note: Check valve must be installed with arrow in the direction as shown.

2. Install Nipple (31) in upper ½" tapped body opening (system port of bypass line) and connect parts in proper order to Union (11). Connect union.

3. Install Nipple (28) in ½" tapped body opening (alarm outlet) and connect parts in proper order to Union (11).

4. Install Nipple (37) in Tee (16) and connect parts in proper order to Union (11) in alarm line. Connect union.

5. Install Nipple (37) in Tee (16) and connect parts in proper order to Union (11) in drain line.

Note: Check valve must be installed with arrow in direction as shown.

6. Install Nipple (26) in 1¼" tapped body opening (drain outlet) and connect parts in proper order to Union (11). Connect union.

Note: Item (23) Drain Orifice P/N 98580002 ½" x ¾" must be installed as shown.

7. Install Retard Orifice (24) in Tee (13) and connect parts in proper order to the retard chamber which is attached to Nipple (27).

8. Install Nipples (42) and (41), Elbows (19), Valves (4), Plugs (10), and Gauges (7).

Trimings for other installation arrangements. (i.e., horizontal variable pressure closed drain, vertical variable pressure open drain, and horizontal variable pressure open drain) are the same as those described above through Step 4. Then continue to trim valves for the appropriate installations using Figure 4, 5 or 6.

When trimming constant pressure valves in the horizontal and vertical positions, install Nipple (39) and Elbow (20) in the ½" tapped body opening (alarm outlet) first, then continue to trim out valve using Figure 7 or 8.

The hinge pin shall be at the top when alarm valves are installed in a horizontal position.

Trim Parts—Model E-1

Item No.	Part No. Galvanized	Description	E1 Variable Pressure Closed Drain		E1 Variable Pressure Open Drain		E1 Constant Pressure	
			6502041210	6502041211	6502041110	6502041111	6502041010	6502041011
			Vertical	Horizontal	Vertical	Horizontal	Vertical	Horizontal
			Number Required		Number Required		Number Required	
1	71010481	Drip Cup Assembly, 1¼"	—	—	1	1	1	1
2	98840106	Valve, Angle, 1¼"	1	1	1	1	1	1
3	98840103	Valve, Angle, ½"	1	1	1	1	1	1
4	98840160	Valve, 3-Way Gauge, ¼"	2	2	2	2	2	2
5	98840181	Valve, Horizontal Check, ½"	2	2	1	1	—	—
6	98840105	Valve, Ball ½"	1	1	1	1	1	1
7	98248001	Gauge, Water Pressure	2	2	2	2	2	2
8	98614401	Plug, ¾"	—	—	—	—	1	1
9	98604406	Plug, ½"	1	1	1	1	2	2
10	98614403	Plug, ¼"	2	2	2	2	2	2
11	98815200	Union, ½"	5	5	3	3	4	4
12	96606611	Tee, 1¼" x 1¼" x ¾"	1	1	—	—	—	—
13	96606612	Tee, ¾" x ½" x ½"	1	1	—	—	—	—
14	96606603	Tee, ½" x ½" x ¾"	—	—	—	—	1	1
15	98761649	Tee, ½" x ¼" x ½"	2	2	2	2	1	1
16	98761651	Tee, ½"	3	3	3	3	3	3
17	98174402	Elbow, ¾"	1	1	1	1	—	—
18	98174401	Elbow, ½"	6	6	5	5	4	4
19	98174404	Elbow, ¼"	3	2	2	2	3	3
20	98048000	Bushing, Hex, ½" x ¼"	—	—	—	—	1	1
21	98048002	Bushing, Restricted Drain, ½"	—	—	—	—	1	1
22	92096521	Orifice, Retard & Drain, ½"x¾"	—	—	1	1	—	—
23	98580002	Orifice, Drain, ½" x ¾"	1	1	—	—	—	—
24	98580001	Orifice, Retard, ¾"	1	1	—	—	—	—
25	98543284	Nipple, 1¼" x 5" Lg.	1	1	—	—	—	—
26	98543240	Nipple, 1¼" x 1½" Lg.	1	1	1	1	1	1
27	98543215	Nipple, ¾" x 1½" Lg.	1	1	1	1	—	—
28	98543211	Nipple, ½" x 6½" Lg.	1	1	—	—	—	—
29	98543202	Nipple, ½" x 5½" Lg.	1	1	—	—	—	—
30	98543219	Nipple, ½" x 5" Lg.	—	—	1	1	—	—
31	98543228	Nipple, ½" x 5½" Lg.	1	1	1	1	—	—
32	98543207	Nipple, ½" x 4½"	2	2	—	—	1	1
33	98543216	Nipple, ½" x 4" Lg.	3	2	1	1	1	1
34	98543230	Nipple, ½" x 3½" Lg.	1	—	1	1	1	1
35	98543210	Nipple, ½" x 3" Lg.	1	1	3	3	—	—
36	98543209	Nipple, ½" x 2½" Lg.	1	2	3	3	3	3
37	98543223	Nipple, ½" x 2" Lg.	12	13	7	7	7	7
38	98543212	Nipple ½" x 1½" Lg.	—	1	2	2	3	3
39	98543270	Nipple, ½" x Close	1	1	—	—	—	—
40	98543236	Nipple, ½" x 1" Lg.	—	—	2	2	—	—
41	98543224	Nipple, ¼" x 8"	2	2	—	—	2	2
42	98543226	Nipple, ¼" x 4½"	2	2	2	2	3	3
43	95169515	Nipple, ¼ x 1½	A/R	A/R	A/R	A/R	A/R	A/R

**Variable Pressure
Closed Retard Drain
Vertical Installation**

Figure 3

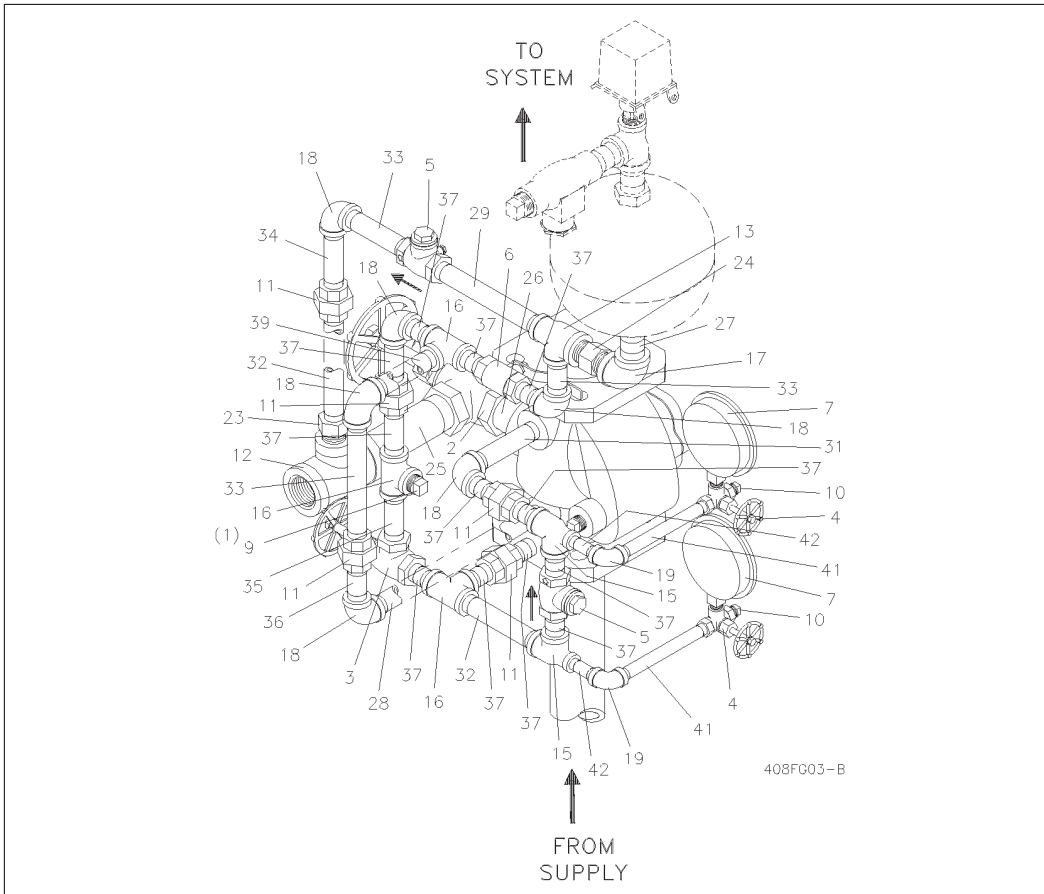

(1) This plug may be removed to install a non-silencable alarm pressure switch.

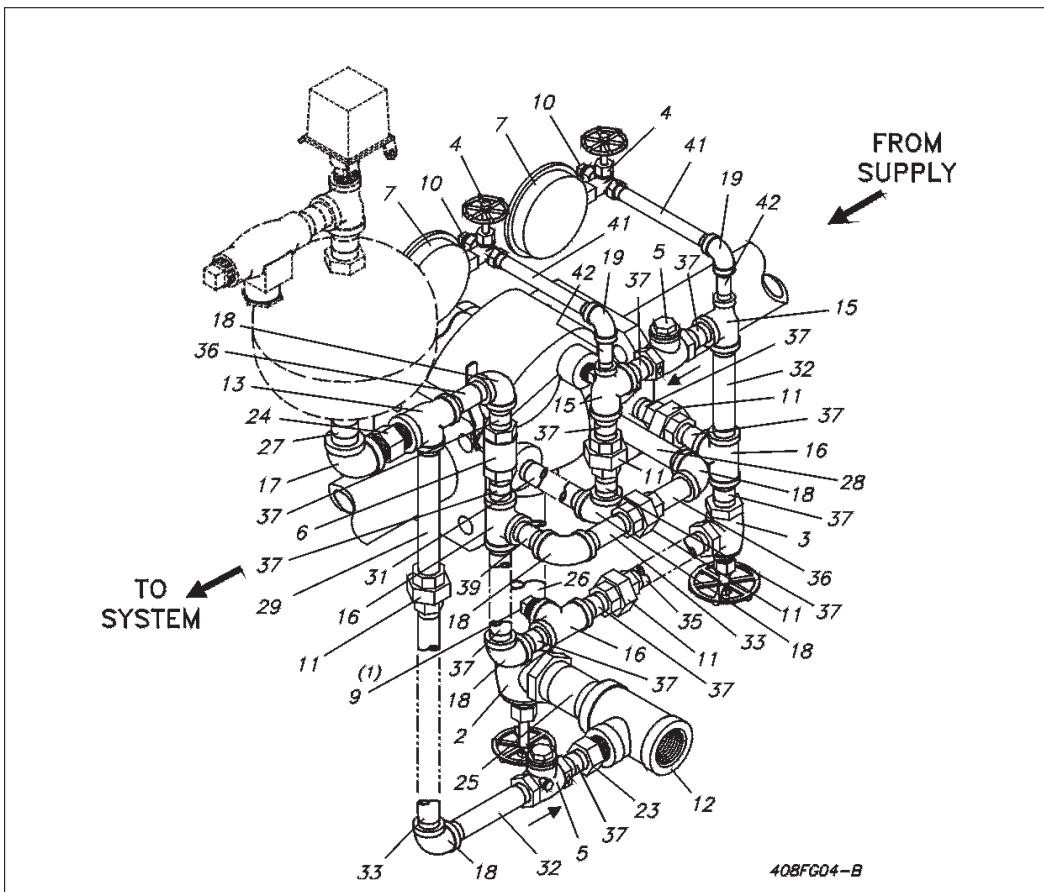

**Variable Pressure
Closed Retard Drain
Horizontal Installation**

Figure 4

**Variable Pressure
Open Retard Drain
Vertical Installation**

Figure 5

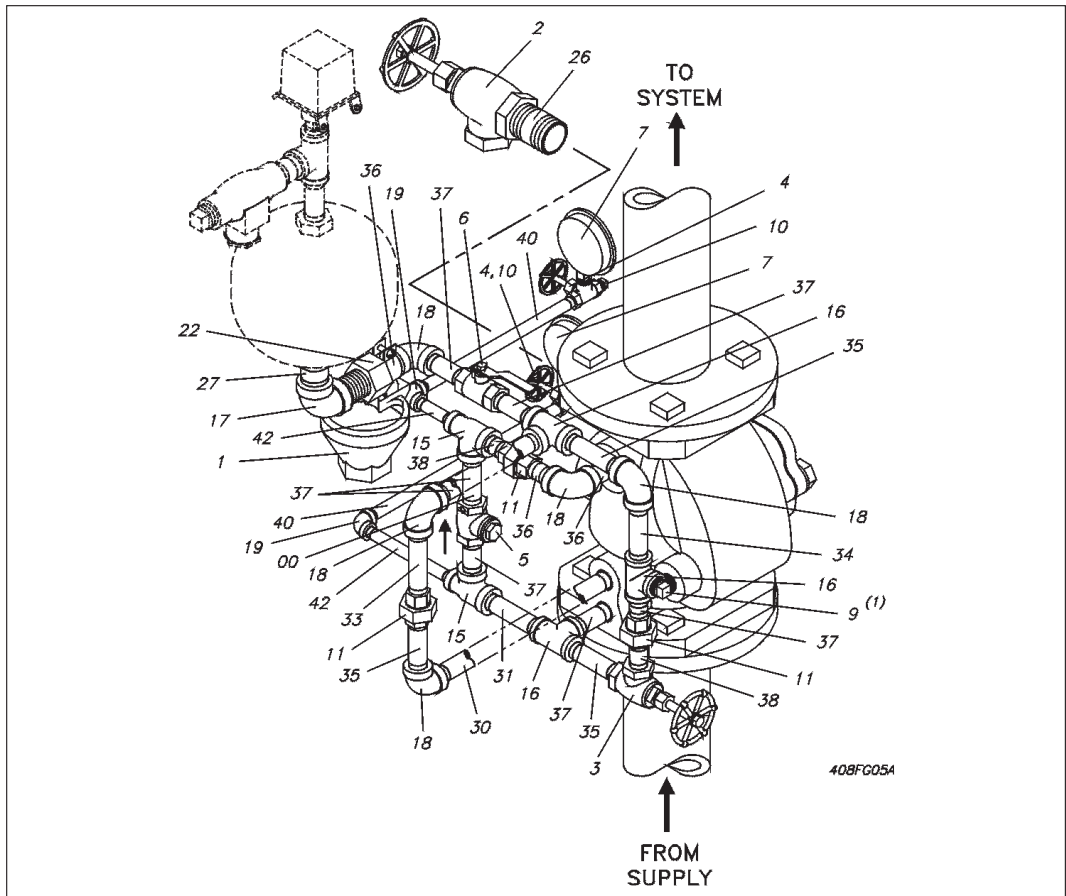

(1) This plug may be removed to install a non-silencable alarm pressure switch.

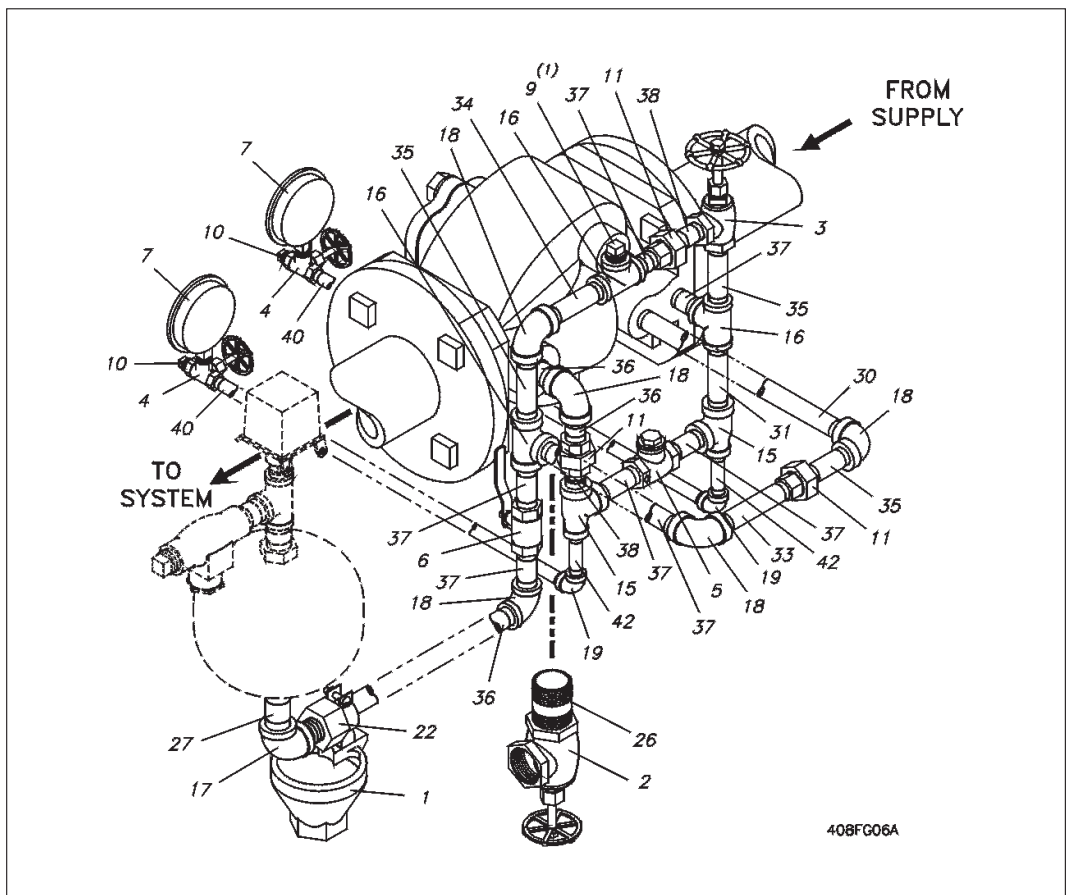

**Variable Pressure
Open Retard Drain
Horizontal Installation**

Figure 6

Constant Pressure Vertical Installation

Figure 7

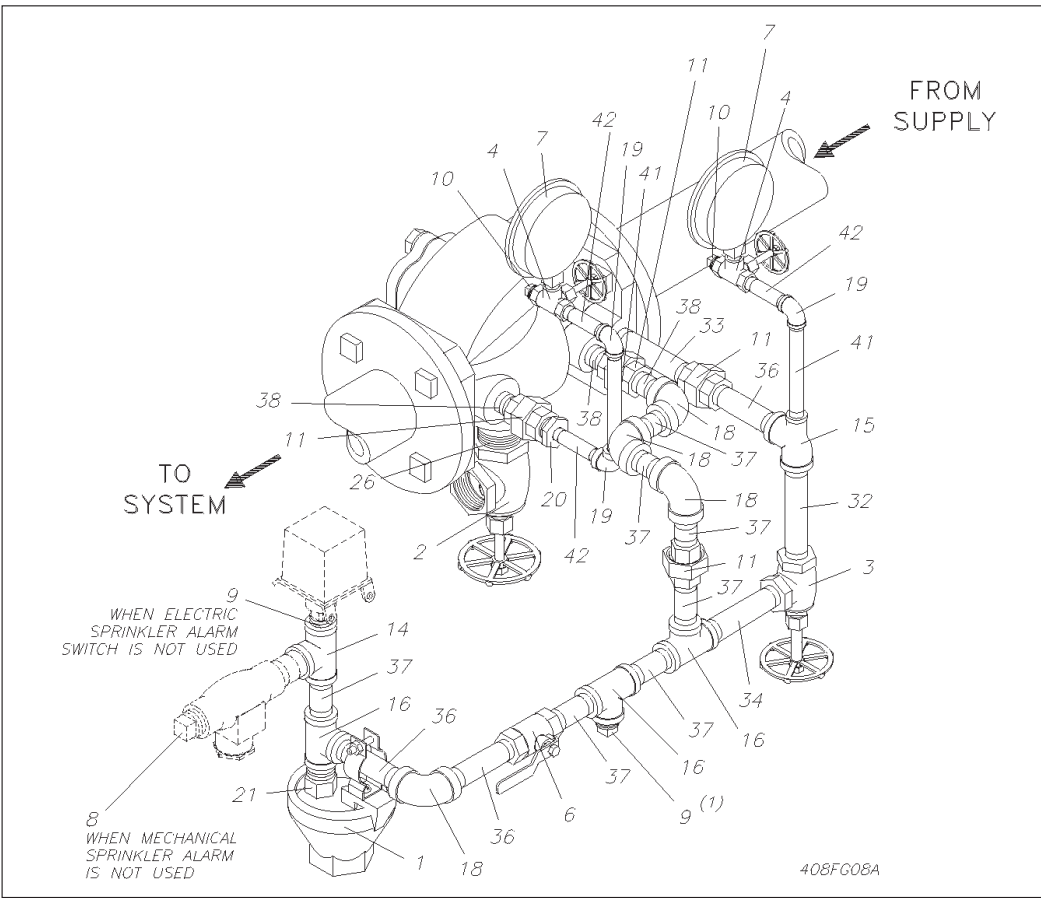
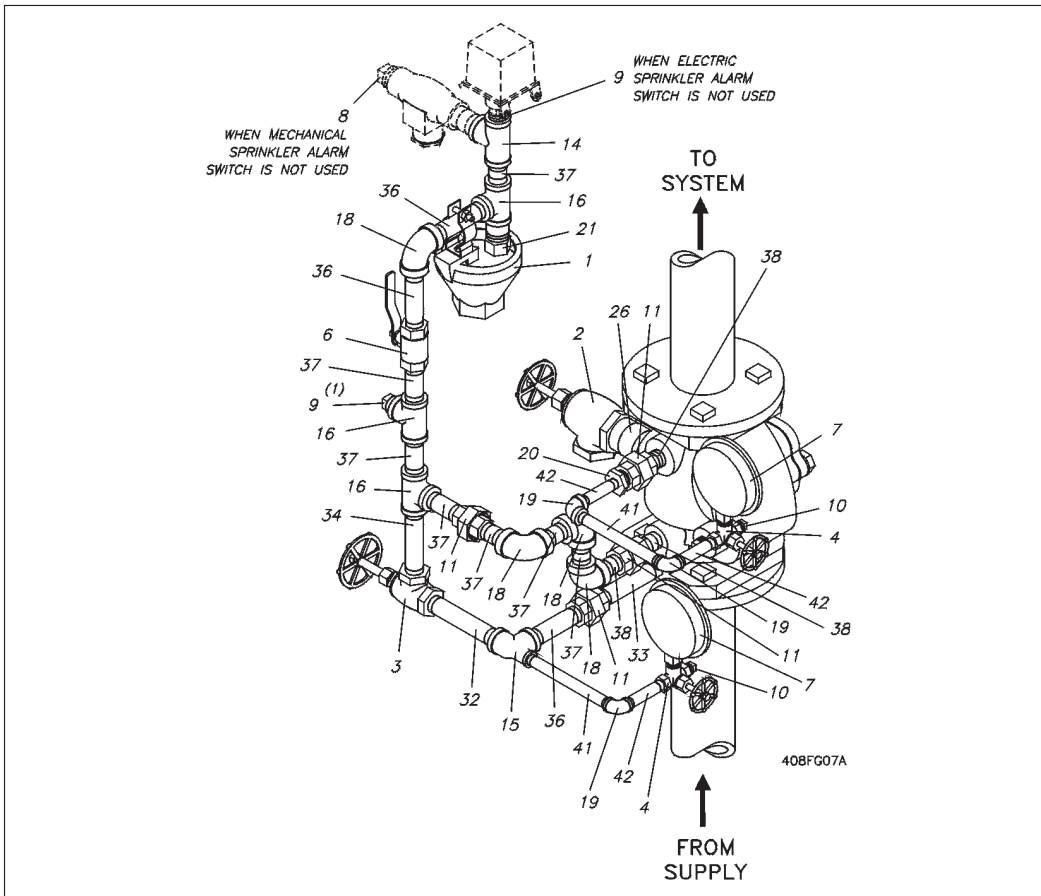

Constant Pressure Horizontal Installation

Figure 8

Installation Measurement in Inches

Valve	A	B	C	D	E	F	G	H	I	J	K	L	M	N	O	P	Q	R
2½" & 3"	7½	11	6	17¼	16	15	5¼	12¾	13½	6¼	14¾	20¼	7	14	8½	25	12¼	10

Variable Pressure, Vertical Trim
Front Elevation

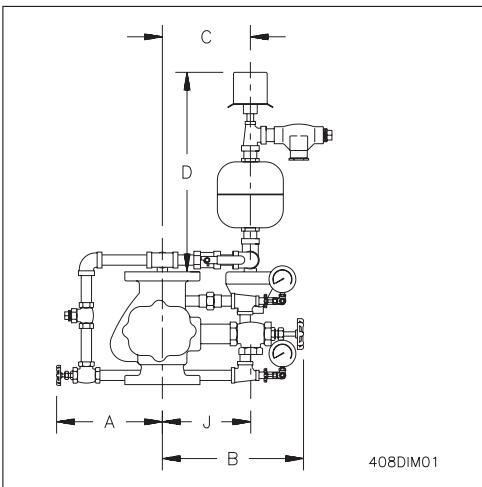

Variable Pressure, Horizontal Trim
Front Elevation

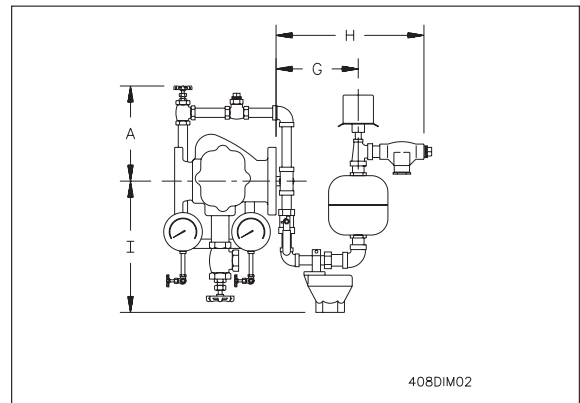

Variable Pressure, Vertical Trim
Top View

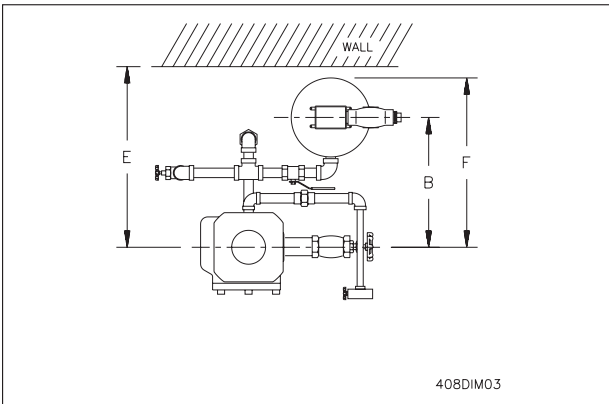

Variable Pressure, Horizontal, Closed Drain Trim
Front Elevation

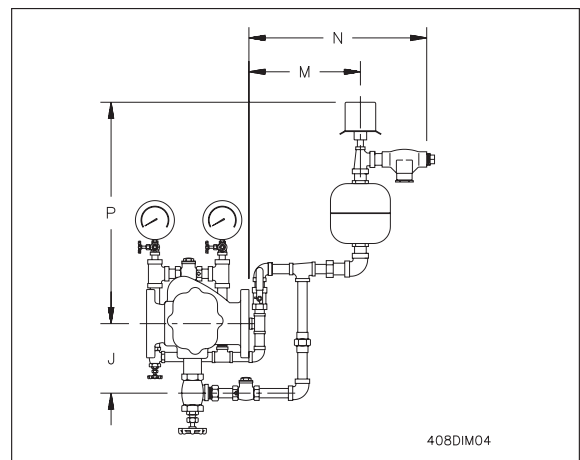

Constant Pressure, Vertical Trim
Front Elevation

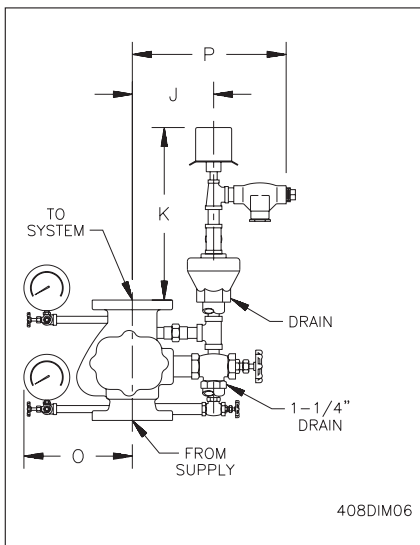

Variable Pressure, Vertical,
Closed Drain Trim
Front Elevation

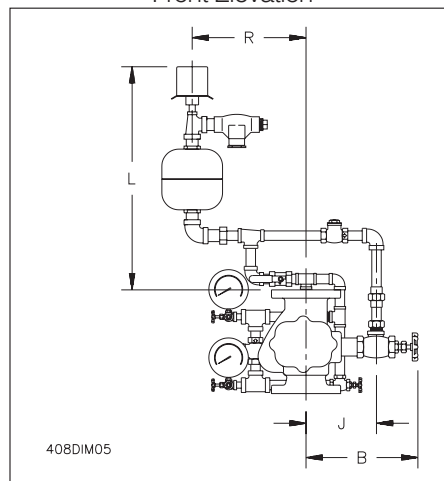

Constant Pressure, Horizontal Trim
Front Elevation

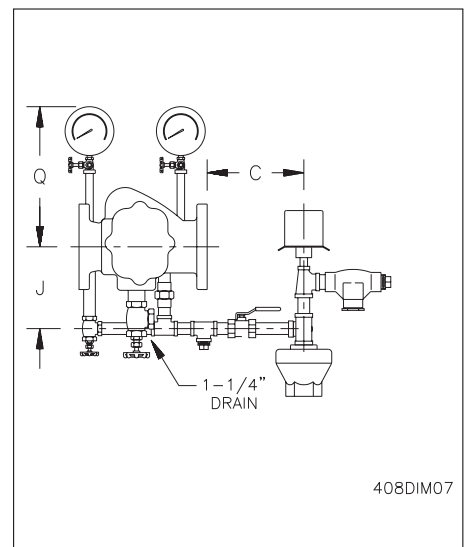

Model E Alarm Valve Parts

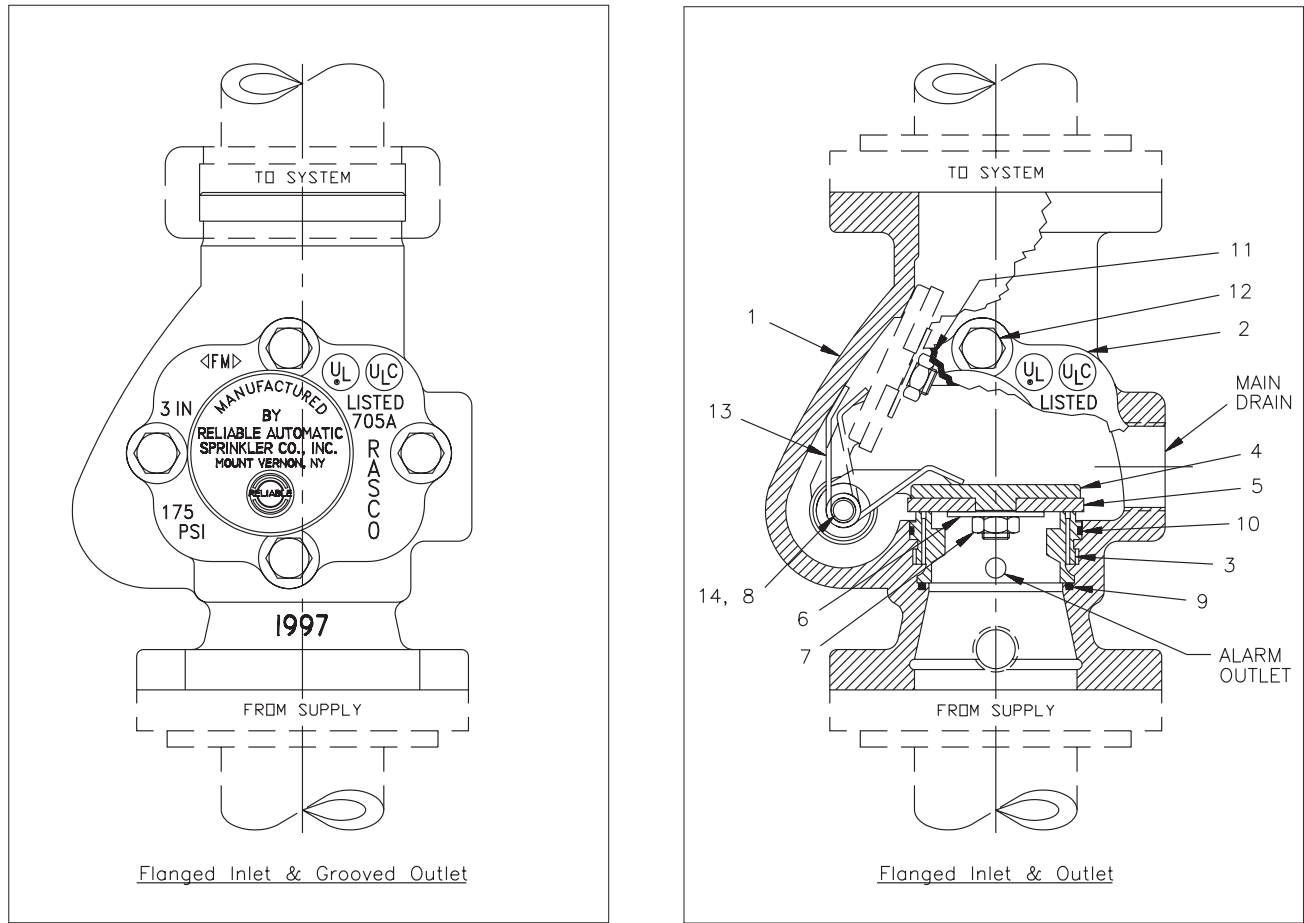

Figure 9

Parts List Alarm Valves and Retard

Item No.	Part Name	Part Number		Quantity	
		2½"	3"	2½"	3"
1	Body,				
	Flanged-U.S. Standard	91006122	91006121	1	1
	Flanged & Grooved-U.S. Std.	—	91006153	—	1
	Metric Flanged	91006120 (65mm)	—	1	—
2	Cover	92116123	92116123	1	1
3	Seat	96016123	96016123	1	1
4	Clapper & Bushing Assembly	71020310	71020310	1	1
5	Clapper Rubber Facing	93406123	93406123	1	1
6	Clamping Ring	95306123	95306123	1	1
7	Clamping Ring Screws or Nut	94906124	94906124	1	1
8	Hinge Pin	95006123	95006123	1	1
9	Seat "O" Ring	95446123	95446123	1	1
10	Seat "O" Ring	95436123	95436123	1	1
11	Cover Gasket	93706123	93706123	1	1
12	Cover Bolts	91106123	91106123	4	4
13	Clapper Spring	96406123	96406123	1	1
14	Shaft Pipe Plug	95206123	95206123	1	1
	Retard Chamber	6303000522	6303000522	—	—

Variable Pressure Equipment

The normal position of alarm valve parts is as shown in Figure 9.

Flow of water in the system piping resulting from the discharge through one or more fused automatic sprinklers causes the Clapper (4) to rise off the grooved Seat (3) and permits water from the supply piping to enter the system. The movement of Clapper (4) on Hinge Pin (8) uncovers the groove in Seat (3) and allows water to flow through the groove into the alarm line (Figure 10) to the retard chamber.

Continual flow of water fills the retard chamber and flows to mechanical and/or electric alarms. (For details on mechanical and electric alarms refer to Bulletins 613 and 608, respectively.) A small amount of water will flow into the drain line through the outlet restriction.

When the water ceases to flow through the alarm valve, Clapper (4) (Figure 9) returns to its seat thus stopping the flow of water to the retard chamber. At the same time the restriction and drain offices allow the retard chamber and alarm line to drain through the drain outlet.

Virtually all sprinkler system piping contains confined air. If a water hammer or pressure surge occurs in the supply line, the increased pressure will compress the confined air and cause the alarm valve clapper to lift intermittently which may result in false alarms.

The Reliable Alarm Valve is designed to prevent false alarms, under these conditions, by two features.

1. The bypass line (Figure 10) with Check Valve (B) allows surges to pass from the supply to the system side of the alarm valve clapper without lifting the clapper off its seat. Repeated surges build up an effective excess

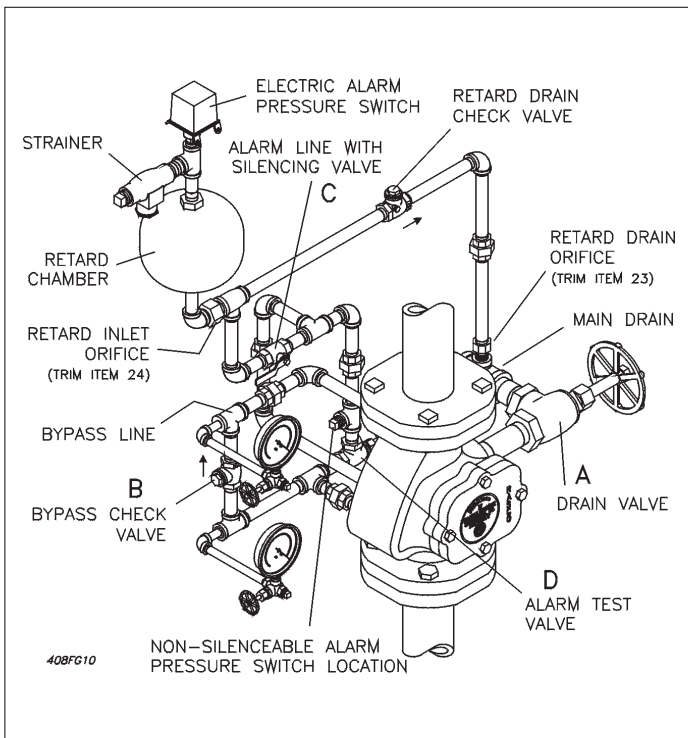

Figure 10

pressure in the system which steadies the clapper and minimizes false alarms. Should a heavy surge force the clapper off its seat and allow water to flow out the alarm line, then the retard chamber comes into action.

2. The retard chamber and the restriction and drain orifices allow intermittent flows to be drained before they can fill the chamber and pass through to operate the electric and mechanical alarms.

Constant Pressure Equipment

The operation of this equipment is the same as described for the variable pressure equipment, except that due to the water supply being constant, the retard chamber is not required and the water on passing through the groove in the seat of the alarm valve flows directly to and operates the electric and mechanical alarms.

Tests

To test the operation of the alarm valve and its alarm equipment, open the inspectors test connection which should cause the mechanical and the electric alarms to sound. This test connection is usually located on the end or top line of the system and its opening is equivalent to the fusing of one automatic sprinkler.

To test the operation of the alarm equipment only, without unseating the alarm valve clapper, open Valve (D) Figure 10. Should the mechanical sprinkler alarm (water motor) not operate, most likely the Model B Strainer is clogged. To clean, remove the strainer cap and filter. Be sure to replace filter and tighten cap securely.

To test supply piping for unobstructed flow, close Valve (C) Figure 10 and open Drain Valve (A). When test is completed make sure to close Drain Valve (A) securely and open and seal Valve (C).

Maintenance

Reliable Alarm Valves and associated equipment shall periodically be given a thorough inspection and test. NFPA 25 provides minimum inspection, testing and maintenance requirements. Alarm valves shall be tested, operated, cleaned, inspected and parts replaced as required, at least annually.

Usually any trouble will be shown by one or more of the following symptoms: A. Mechanical Sprinkler Alarm (water motor) not operating (See TESTS above for corrective measures). B. Steady Water Flow Into Drip Cup; C. False Alarms and D. Intermittent Alarms. If the following does not correct the condition it is recommended that an authorized Reliable contractor be contacted.

B. Steady Water Flow Into Drip Cup

Steps in the following sequence should be taken until the steady water flow into drip cups stops:

1. Open Drain Valve (A), Figure 10, which should flush any loose matter off alarm valve seat. Close valve and observe if water flow continues.

2. Open Valve (D), Figure 10, which should flush any loose matter off its seat. Close valve and observe if water flow continues.
3. Open Union (11), Figures 3 thru 8, and observe if water flows from the alarm valve alarm outlet or through Valve (D), Figure 10. If through Valve (D), close main control valve, then open and inspect Valve (D). Repair as necessary and reinstall. Close Union (11) Figures 3 thru 8, then open main supply valve.
4. Close main control valve to determine if water flow is coming from above or below alarm valve clapper.

Note: Supply pressure gage should read zero when main control valve is closed tight and water pressure between this valve and the alarm valve is relieved. If necessary to relieve water pressure, open Valve (D), Figure 10. When water stops running at drip cup, close Valve (D).

 - a. If water flow is coming from below clapper, water will stop running at drip cup.
 - b. If water flow is coming from above clapper, water will continue to run at drip cup.

Note: To minimize downtime, the following parts should be on hand before the valve is disassembled:

 - 1) Seat Installation Wrench: 2½" and 3"—Part number 688123000.
 - 2) Clapper Rubber Facing: Item 5, Figure 9.
 - 3) Seat "O" Rings: Items 9 and 10, Figure 9.
- c. In either case, drain system by opening Drain Valve (A) Figure 10. Remove Cover (2) Figure 9 Shaft Pipe Plug (14), Hinge Pin (8) and Clapper Assembly (4).

Note: Hold down Spring (13) when removing Hinge Pin (8).
- d. Carefully inspect for the following:
 - 1) Damage to clapper rubber facing—inspect surface for imbedded foreign matter. Replace facing if found damaged. (Be certain that clapper and clapper clamping ring surfaces are thoroughly cleaned before assembling with new facing.)
 - 2) Damage to seat surface—clean seat thoroughly. Inspect for any nicks in seat or for stones or other foreign matter lodged in seat groove. If seat or other parts of valve are found to be damaged, they must be replaced.
- e. To replace seat "O" rings—
 - 1) Using the seat wrench, unscrew the seat. Use care to avoid damage to the seat surface.
 - 2) Remove "O" rings, Items 9 and 10, Figure 9. Thoroughly clean "O" ring grooves and sealing surfaces. Inspect for damage or foreign material.
 - 3) Apply a light coat of lubricant to new "O" rings and install in the proper grooves. Use care to avoid stretching, twisting or other damage to "O" rings.
 - 4) After checking that "O" rings are correctly installed, carefully reinstall seat and tighten securely with wrench.
- f. To reassemble alarm valve—

Replace clapper assembly on seat in alarm valve—insert Hinge Pin (8) in valve and pass it through one bearing of Clapper (4)—press and hold Spring (13) securely in position be-

tween clapper arm bearings and push clapper arm shaft through spring coils to far side of valve—replace Shaft Pipe Plug (14).

- 2) Lift toe of clapper—check for non-binding movement and proper seating.
- 3) Replace Cover (2) being sure Cover Gasket (11) is in position and bolts and nuts are securely tightened.
- 4) Close Drain Valve (A) Figure 10. Slowly open and seal main control valve. Be sure Valve (C) is sealed in open position.

C. False Alarms

False alarms are generally caused by pressure surges in the water supply and can occur if the system loses its effective excess pressure. A visual indication of this condition is given by similar readings on the system and supply pressure gauges. One or more of the following will contribute to this loss of pressure—leaking system drain valves, leaking at the alarm valve Seat (3), Figure 9, leaking between the Clapper (4) and the Facing (5) or leaking at the bypass Check Valve (B), Figure 10. Corrective Steps:

1. Check system drain valves for tightness.
2. In order to find and correct a leak at the alarm valve seat proceed as outlined in "B" (1. Through 4.)
3. To correct a leak between the clapper and the clapper facing proceed as outlined in "B" 4(c) and "B" 4(d)(1).
4. In order to find and correct a leak through the bypass check valve, proceed as follows:
 - a. Close the main control valve and open Valve (D) Figure 10 to relieve pressure between main control valve and clapper of alarm valve. Open Union (11) near the alarm port, Figures 3 thru 6. A steady leak at the union indicates the bypass Check Valve (B) Figure 10 has foreign matter under the seat or the clapper rubber facing needs replacing.
 - b. If bypass Check Valve (B) is leaking, repair after opening Drain Valve (A) and draining system.
 - c. Connect union, close Valves (A) and (D) and then slowly open and seal main control valve.
5. If retard chamber and mechanical sprinkler alarm lines do not drain completely, false alarms may result. In this case, check Retard Drain Orifices (22 or 23) and Drain Check Valve (7), Figures 3 thru 6, to ensure they are not plugged and are operating properly.

D. Intermittent Alarms

Intermittent alarms are the result of excessive confined air trapped in the sprinkler system piping. To correct this problem, fill the system slowly while venting air at all system openings and at all system high points including sprinkler connections if necessary.

Contact the installing contractor or Reliable if any difficulties are experienced. Should replacement parts be needed, use only Reliable made parts. When ordering, specify part number, name, size, model and serial number of the unit.

Pressure Relief Trim Kits

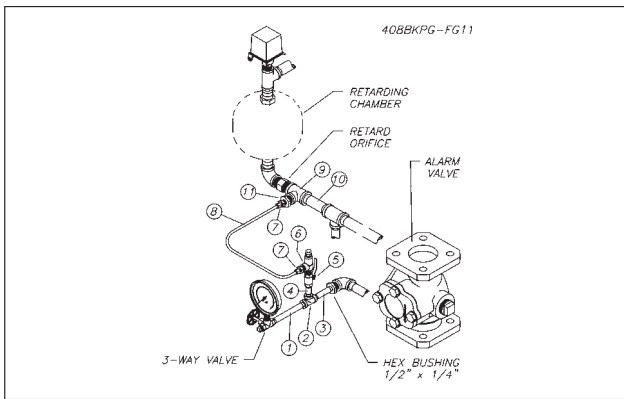

Figure 11—Closed Retard Drain. FM Approved

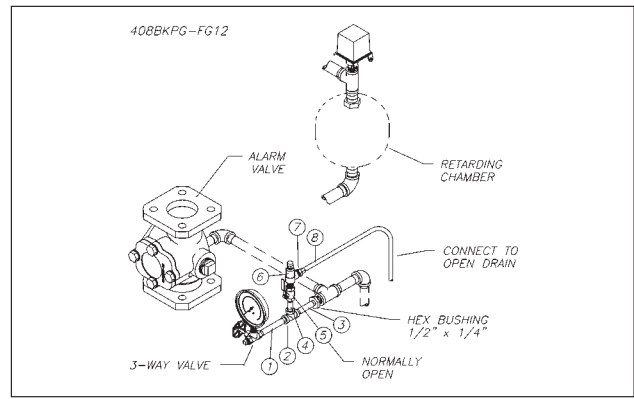

Figure 12—Open Retard Drain. FM Approved

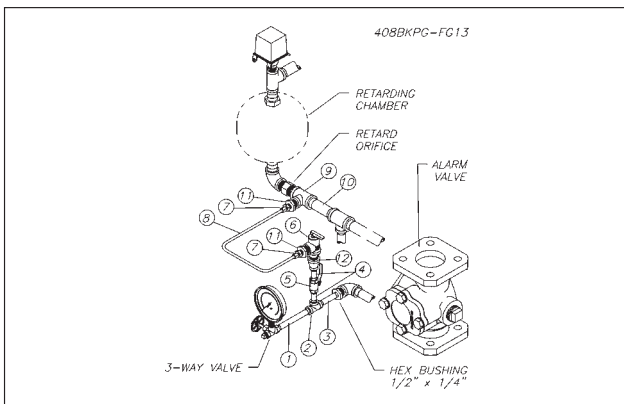

Figure 13—Closed Retard Drain. UL Listed.

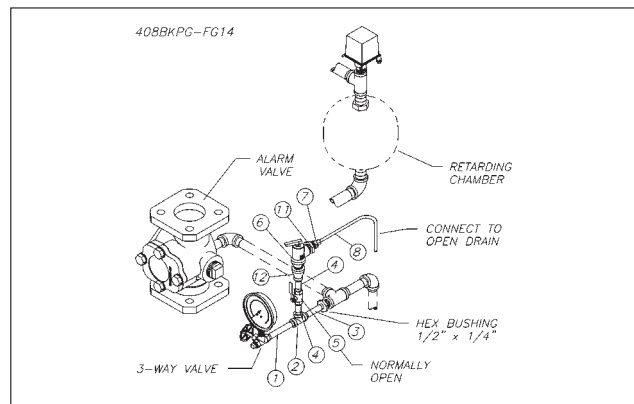

Figure 14—Open Retard Drain. UL Listed.

Trim Kits for both Open and Closed Retard Drain Include All Listed Parts.

Item No.	Part Name	Part Number	Quantity			
			Galvanized	Fig.11	Fig.12	Fig. 13
1	Nipple— $\frac{1}{4}$ " x 3"	98523219	1	1	1	
2	Tee— $\frac{1}{4}$ " x $\frac{1}{4}$ " x $\frac{1}{4}$ "	98761606	1	1	1	
3	Nipple— $\frac{1}{4}$ " x 2"	98573220	1	1	1	
4	Nipple— $\frac{1}{4}$ " x 1 $\frac{1}{2}$ "	98523213	1	1	1	
5	Ball Valve— $\frac{1}{4}$ " NPT	98840107	1	1	1	
6	Relief Valve (175 psi) - $\frac{1}{4}$ " NPT, FM	98840191	1	1	—	—
	Relief Valve (185 psi) — $\frac{1}{4}$ " NPT	98840192				
	Relief Valve (175 psi) - $\frac{1}{2}$ " , YΛ	98840194				
7	Connector, Male— $\frac{1}{4}$ " NPT x $\frac{1}{4}$ " Tube	98085630	2	1	2	1
8	Tubing, Copper— $\frac{1}{4}$ " x 16 $\frac{1}{2}$ "	98768000	1	1	1	1
9	Tee— $\frac{3}{4}$ " x $\frac{3}{4}$ " x $\frac{1}{2}$ "	98761602	1	—	1	—
10	Nipple— $\frac{3}{4}$ " x 1 $\frac{1}{2}$ "	98523203	1	—	1	—
11	Reducer Bushing— $\frac{1}{2}$ " x $\frac{1}{4}$ "	98048020	1	—	1	1
12	Reducer Coupling, $\frac{1}{2}$ " x $\frac{1}{4}$ "	98085666	—	—	1	1

Pressure Relief Trim Kits

175 PSI - FM	185 PSI - FM	175 PSI - UL	Type
P/N 6502050102	P/N 6502050101	P/N 6502050100	Galvanized

The equipment presented in this bulletin is to be installed in accordance with the latest pertinent Standards of the National Fire Protection Association, Factory Mutual Research Corporation, or other similar organizations and also with the provisions of governmental codes or ordinances whenever applicable.

Products manufactured and distributed by Reliable have been protecting life and property for over 80 years, and are installed and serviced by the most highly qualified and reputable sprinkler contractors located throughout the United States, Canada and foreign countries.

Manufactured by



The Reliable Automatic Sprinkler Co., Inc.

800.431.1588
800.848.6051
914.668.3470
www.reliablesprinkler.com

Sales Offices
Sales Fax
Corporate Offices
Internet Address

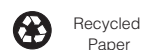

Revision lines indicate updated or new data
PG. Printed in U.S.A. 10/06 P/N9999970049