



## TECHNICAL DATA

### ACCELERATOR MODEL E-1

The Viking Corporation, 210 N Industrial Park Road, Hastings MI 49058

Telephone: 269-945-9501 Technical Services 877-384-5464 Fax: 269-945-4495 Email: techsvcs@vikingcorp.com

#### 1. PRODUCT DESCRIPTION

The Viking Model E-1 Accelerator is a quick-opening device. When installed with the required external Anti-flood Device, the assembly is designed to increase the operating speed of Viking Model F Dry Pipe Valves. An accelerator (quick-opening device) is recommended on all differential dry pipe valves and is required on dry pipe systems of certain capacities. Refer to Installation Standards and Authorities Having Jurisdiction. The Viking Model E-1 Accelerator may also be used (without the external Anti-flood Device) to speed the action of pneumatic release systems on deluge, flow control, or preaction systems.

##### Features

- Automatically resets
- External Anti-flood Assembly
- UL listed for use on systems of maximum capacity allowed
- Factory Tested

#### 2. LISTINGS AND APPROVALS

UL Listed - VJPZ (requires Model B-1 Anti-flood Device)

ULC Listed (requires Model B-1 Anti-flood Device)

FM Approved - Accelerators and Exhausters (requires Model B-1 Anti-flood Device)

VdS Approved - G4960044, G4960045, G4960046, G4960047 (requires Model B-2 Anti-flood Device)

New York City Department of Buildings - MEA 89-92-E



#### 3. TECHNICAL DATA

##### Specifications:

Shipping Weight: Accelerator Package: 12 lbs (5,4 kg)

##### Material Standards:

Refer to Figure 1

##### Ordering Information:

Available since 1993

Part Numbers:

Model E-1 Accelerator - 08055

Model B-1 Anti-flood Device - 08061

Model B-2 Anti-flood Device - 09391 (Vds approved)

Accelerator & Anti-Flood Package - Part No. 08116 Includes Model E-1 Accelerator and Model B-1 Anti-flood Device

##### Accessories:

Model E-1 Accelerator Trim Kit (galvanized steel) for installation on Viking Model F Dry Valves (all sizes). Includes one air gauge. Viking Part No. 08264

Viking Technical Data may be found on The Viking Corporation's Web site at <http://www.vikinggroupinc.com>. The Web site may include a more recent edition of this Technical Data Page.

#### 4. INSTALLATION

##### A. On Dry Valve Trim:

Verify that the water supply piping has been adequately flushed to reduce the opportunity for foreign matter to contaminate sprinkler piping and/or trim components.

Install the Model E-1 Accelerator in the Dry Valve trim piping according to the Model E-1 Accelerator Trim Chart provided with accelerator.

A Viking Anti-flood Device is required when the Model E-1 Accelerator is installed on a dry valve. The Model B-1 Anti-flood Device is for use with UL and ULC Listed and/or FM Approved dry valve trim. The Model B-2 Anti-flood Device is for use with VdS Approved dry valve trim.

The dry system air supply must be connected as shown on the trim chart.

##### B. On Pneumatic Release System

Connect the Model E-1 Accelerator to a ½" (15 mm) NPT air inlet nipple connected to the Pneumatic Release System piping at the location shown on drawings provided in the Technical Data for the system used.

The external Anti-flood Device is not required when the Model E-1 Accelerator is installed on a Pneumatic Release system.

A ½" (15 mm) NPT ball valve should be installed between the accelerator and the point of connection to the Pneumatic Release System to allow the accelerator to be removed without placing the Pneumatic Release System out of service. The ½" (15 mm)



## TECHNICAL DATA

### ACCELERATOR MODEL E-1

The Viking Corporation, 210 N Industrial Park Road, Hastings MI 49058

Telephone: 269-945-9501 Technical Services 877-384-5464 Fax: 269-945-4495 Email: techsvcs@vikingcorp.com

NPT ball valve should be normally locked open.

Follow installation instructions in Paragraph 4.C. "General Installation Instructions".

#### C. General Installation Instructions

Air supply should be from an automatic, regulated, and restricted source supplied with clean, dry, oil-free air (or nitrogen). Devices used should be specifically listed for such service. A Viking Air Maintenance Device and an appropriately sized dehydrator are recommended.

When corrosive atmospheres and/or contaminated water supplies are present, it is the owner's responsibility to verify compatibility with the Model E-1 Accelerator and associated equipment.

1. Remove all plastic thread protectors from the openings of the accelerator.
2. Apply a small amount of pipe-joint compound or tape to the external threads of all pipe connections required. Take care not to allow any compound, tape, or other foreign matter inside any of the nipples or openings of the accelerator or trim.
3. Either of the two ½" (15 mm) NPT threaded openings, located on opposite sides of the accelerator base, may be used to connect the accelerator to trim piping. A ½" (15 mm) NPT plug (included) must be installed in the opening not used.
4. The Model E-1 Accelerator must be installed upright (with the air gauge opening at the top) as shown on the trim chart.
5. Do not obstruct the opening in the bottom of the accelerator. The opening must remain unobstructed in order to vent to atmosphere. Do not attempt to plug the opening in the bottom of the accelerator.
6. Install a 0-80 PSI (0-5.5 bar) Retard to 250 PSI 17.2 bar) air gauge in the 1/4" (8 mm) NPT opening in the top of the accelerator.
7. DO NOT expose the accelerator to the hydrostatic test.

#### D. PLACING ACCELERATOR IN SERVICE

##### I. On Dry Valve Trim

When the dry pipe system is ready to be placed in service, verify that all equipment is adequately heated and protected to prevent freezing and physical damage.

1. With the water supply main control valve CLOSED, drain all water from the dry pipe system. If the system has operated, open all low point drains and the system flow test valve. Allow enough time to completely drain the system.
2. Verify that the intermediate chamber of the dry valve is free of water. No water should flow from the drip check when the plunger is pushed.
3. Reset the dry valve. (Refer to individual technical data for the dry valve.)
4. Close all low point drains, the system flow test valve, and the priming water level test valve in the dry valve trim.
5. Close the ½" (15 mm) NPT Anti-flood isolation valve\*\*.
6. Observe the air pressure gauge on top of the accelerator. The gauge must read zero before the accelerator will automatically reset. It may be necessary to loosen, remove, and re-install the accelerator air gauge (use the appropriate wrench) to vent trapped air pressure from the upper chamber even when the gauge indicates zero if the air supply is on while performing this step.
7. Pressurize the system in accordance with recommended settings. See technical data for the dry system used. Do not exceed 60 PSI (4.1 bar).
8. When air pressure on the accelerator air gauge equals the system set pressure, open and secure the ½" (15 mm) NPT Anti-flood isolation valve\*\*.
9. When the air pressure on the accelerator air gauge equals the system set pressure, perform Dry Pipe Valve Priming Water level Test described in paragraph 6.B.I to verify that water is not present above the Priming Level Test Valve in the dry valve trim. This test is important because any water columning (accumulation of water above the Priming Level Test Valve) can slow or even prevent the dry valve clapper from opening when the dry system operates. Priming water is NOT required for Viking Dry Valves. If the presence of water is detected above the Priming Level Test Valve, the system may not have been properly drained. To verify that the system has been properly drained, repeat steps 1 through 8 above as required.

**NOTE: THIS STEP (STEP 9) IS REQUIRED ANY TIME WATER HAS ENTERED THE SPRINKLER PIPING. IF NO WATER HAS BEEN ALLOWED TO ENTER THE SYSTEM SINCE THE PREVIOUS PRIMING WATER LEVEL TEST, THIS STEP MAY NOT BE REQUIRED.**

10. Open the main drain valve (located on the inlet of the dry valve).
11. Slowly open the water supply main control valve.
12. When flow is developed from the main drain, close the main drain valve.
13. Fully open and secure the water supply main control valve supplying the dry valve.
14. Verify that the ½" (15 mm) NPT anti-flood isolation valve is open and secure\*\*.
15. Secure all valves in their normal operating position.
16. Notify Authorities Having Jurisdiction and those in the affected area that the system is in service.

\*\* VdS approved systems equipped with the Model B-2 Anti-flood Device do not include an isolation valve. Proceed to next step.



## TECHNICAL DATA

### ACCELERATOR MODEL E-1

The Viking Corporation, 210 N Industrial Park Road, Hastings MI 49058

Telephone: 269-945-9501 Technical Services 877-384-5464 Fax: 269-945-4495 Email: techsvcs@vikingcorp.com

#### II. On a Pneumatic Release System

When the pneumatic release system is ready to be placed in service, verify that all equipment is adequately heated and protected to prevent freezing and physical damage.

1. Observe the air pressure gauge on top of the accelerator. The gauge must read zero before the accelerator will automatically reset. (It may be necessary to loosen the air gauge to vent the trapped air pressure in the upper chamber.)
2. Pressurize the system according to recommended settings. See technical data for pneumatic release operation of the system used.
3. Open the ½" (15 mm) NPT Ball Valve (if provided) located between the accelerator and the point of connection to the pneumatic release system.
4. When the air pressure on the accelerator gauge equals the system set pressure, proceed with placing the system in service. Refer to technical data for the system used.
5. Verify that the water supply main control valve is open and secure, drain valves are closed, and all other valves are secured in their normal operating position.
6. Notify Authorities Having Jurisdiction and those in the affected area that the system is in service.

#### 5. OPERATION (Refer to Figure 1)

The Viking Model E-1 Accelerator operates on the principle of unbalanced pressures. As the accelerator is pressurized, air enters the inlet chamber, goes through the screen filter (7) into the middle chamber and through an orifice into the lower chamber. From the middle chamber, air slowly enters the upper chamber through a filtered orifice restriction in the cover diaphragm (13).

In the SET position, air pressure is the same in all chambers.

When a sprinkler or release device operates, pressure in the middle and lower chambers is reduced at the same rate as the system pressure. The orifice restriction in the cover diaphragm (13) restricts the air flow from the upper chamber, temporarily causing higher pressure in the upper chamber. The higher pressure forces the cover diaphragm (13) and actuator rod (10) down. This action releases the pressure from the lower chamber to the outlet vent allowing residual pressure in the inlet chamber to force the clapper diaphragm (3) open. After the clapper diaphragm (3) opens, any pressure remaining in the inlet chamber and associated piping is vented to atmosphere.

##### A. On Dry Valve Installations

When properly installed and maintained, only air is exhausted from the vent in the bottom of the accelerator when it operates. A ½" (15 mm) spring loaded check valve\* is installed in the air supply piping between the Model E-1 Accelerator and the air inlet to the dry valve. This check valve, along with the external anti-flood device, prevents water from entering the accelerator after it operates.

\* The ½" (15 mm) spring loaded check valve is included with Model F Dry Valve trim kits.

#### 6. INSPECTIONS, TESTS AND MAINTENANCE

Prior to performing any work on the system in which the Model E-1 Accelerator is installed, refer to Technical Data for the System and equipment used.

**NOTICE: THE OWNER IS RESPONSIBLE FOR MAINTAINING THE FIRE PROTECTION SYSTEM AND DEVICES IN PROPER OPERATING CONDITION.**

The Viking Model E-1 Accelerator must be kept free of foreign matter, freezing conditions, corrosive atmospheres, contaminated water supplies, and any condition that could impair its operation or damage the device.

It is imperative that the system be inspected and tested on a regular basis. The frequency of the inspections may vary due to contaminated water supplies, corrosive water supplies, corrosive atmospheres, as well as the condition of the air supply to the system. For minimum maintenance and inspection requirements, refer to NFPA 25. In addition, the Authority Having Jurisdiction may have additional maintenance, testing, and inspection requirements which must be followed.

**WARNING: ANY SYSTEM MAINTENANCE WHICH INVOLVES PLACING A CONTROL VALVE OR DETECTION SYSTEM OUT OF SERVICE MAY ELIMINATE THE FIRE PROTECTION CAPABILITIES OF THAT SYSTEM. PRIOR TO PROCEEDING, NOTIFY ALL AUTHORITIES HAVING JURISDICTION. CONSIDERATION SHOULD BE GIVEN TO EMPLOYMENT OF A FIRE PATROL IN THE AFFECTED AREAS.**

##### A. INSPECTION

###### I. After every operation and each time water is allowed to enter the system:

1. Prior to pressurizing the system, remove the ½" NPT (15 mm) plug from the base of the accelerator.
2. Inspect the interior of the accelerator for the presence of water. Dampness or condensation may indicate that the air supply is not being dried adequately. An accumulation of water in the accelerator inlet chamber and associated trim piping may indicate that the float check valve (located between the accelerator and the air inlet to the dry valve) is fouled



## TECHNICAL DATA

## ACCELERATOR MODEL E-1

The Viking Corporation, 210 N Industrial Park Road, Hastings MI 49058

Telephone: 269-945-9501 Technical Services 877-384-5464 Fax: 269-945-4495 Email: techsvcs@vikingcorp.com

open, allowing system water to leak past the seat when the dry valve operates filling the system with water. If water is allowed to enter the middle and/or upper chamber of the accelerator, it may contaminate the accelerator orifices and may prevent it from operating properly. Also, when the system operates, if water is allowed to flow into the inlet chamber of the accelerator, water will flow out of the vent opening in the bottom of the accelerator until water supply to the dry valve is shut off.

3. If dampness is found, take appropriate steps to ensure the air supply is adequately dried.
4. If an accumulation of water is found in the accelerator inlet chamber and associated trim piping, conduct an internal inspection of the spring loaded check valve. Clean the seat and or clapper as required.
5. When the inspection is finished, replace the ½" (15 mm) NPT plug removed in step 1 above.

### II. Accelerators installed on dry systems or pneumatic release systems:

Weekly inspection is recommended. If the system is equipped with a low air (or nitrogen) alarm, monthly inspections may be adequate.

1. Check the air pressure gauge located on the top of the accelerator. Air pressure in the upper chamber of the accelerator should equal the air pressure maintained in the system on which it is installed. A difference in pressures other than slight variation due to gauge calibration tolerance may indicate: Gauge malfunction, plugged accelerator orifices and/or filters, or other maintenance is required. See Maintenance paragraph 6.C.II-IV.

**NOTE: STANDARD TOLERANCE ALLOWANCE IN PRESSURE GAUGE CALIBRATION MAY RESULT IN A SLIGHT VARIATION WHEN PRESSURE READINGS OF ANY TWO GAUGES ARE COMPARED.**

2. Check position of ½" (15 mm) NPT Ball Valve.
  - a. For Model E-1 Accelerators installed on dry valves, verify that the ½" (15 mm) NPT Anti-flood isolation valve is OPEN and secured\*\*.
  - b. For Model E-1 Accelerators installed on pneumatic release systems, verify that the ½" (15 mm) ball valve (if provided) located between the accelerator and the point of connection to the pneumatic release system is OPEN and secured.
3. Verify that all other trim valves are in their appropriate normal operating position.
4. Check for signs of mechanical damage and/or corrosive activity. If detected, perform maintenance as required or, if necessary, replace the device.
5. Verify that accelerator and trim are adequately heated and protected to prevent freezing and physical damage.

\*\* VdS approved systems equipped with the Model B-2 Anti-flood Device do not include an isolation valve. Proceed to next step.

### B. TESTS

#### I. Dry Pipe Valve Priming Water level Test & Low-Air Alarm Test

The Priming Water Level Test is recommended quarterly and each time the system is placed in service after water has entered the system. Also, each time the system is placed in service after water has entered the system it is good practice to repeat the Priming Water Level Test within one week. Testing is to verify that the system has been properly drained and that no water is present above the Priming Level Test Valve in the dry valve trim after draining the system. Any water columning (accumulation of water above the Priming Level Test Valve) can slow or even prevent the Dry Valve Clapper from opening when the dry system operates.

Quarterly testing of Low-Air Alarms is recommended.

Semi-annual testing of accelerators is recommended. Conduct Non-Flow Test when Partial Flow Test or Full Flow Test is not required (see paragraph 6.B.III titled Flow Testing on Dry Valves).

1. Notify the Authority Having Jurisdiction and those in the area affected by the test.
2. Close the water supply main control valve supplying the dry valve.
3. Open the main drain valve (located on the inlet of the dry valve).

**NOTE: PERFORMING STEPS 4 OR 5 OF THIS TEST WILL CAUSE THE ACCELERATOR TO OPERATE. A BURST OF AIR FROM THE VENT IN THE BOTTOM OF THE ACCELERATOR WILL INDICATE OPERATION OF THE ACCELERATOR. HOWEVER, WITH THE WATER SUPPLY MAIN CONTROL VALVE CLOSED, AND THE MAIN DRAIN VALVE OPEN, OPERATION OF THE ACCELERATOR SHOULD NOT TRIP THE DRY VALVE.**

4. Dry Valve Priming Water Level Test:
 

Verify that the water supply main control valve is closed and the main drain valve is open.  
Close the Air Supply.

  - a. Fully open the Priming Level Test Valve in the dry valve trim to check for the presence of water. If the presence of water is detected, the system may not have been properly drained. Perform steps 1 through 9 of 4.D.I - Placing the Accelerator in Service.
  - b. When test is complete; if/when no water is detected, open the air supply and continue to step 6.



## TECHNICAL DATA

### ACCELERATOR MODEL E-1

The Viking Corporation, 210 N Industrial Park Road, Hastings MI 49058

Telephone: 269-945-9501 Technical Services 877-384-5464 Fax: 269-945-4495 Email: techsvcs@vikingcorp.com

5. Low Air Alarm Test and Non-Flow Accelerator Test:
  - a. Verify that the water supply main control valve is closed and the main drain valve is open.
  - b. Gradually open the Priming Level Test Valve in the trim of the dry valve to simulate operation of the dry system
    - i. Observe and record the pressure at which the low air alarm operates.
    - ii. Observe the vent in the bottom of the accelerator. A burst of air from the vent in the bottom of the accelerator indicates that the accelerator has operated. No water should flow from the vent. A spurt of water from the vent may indicate that the air supply is not being dried adequately or that the spring loaded check valve (located between the accelerator and the air inlet to the dry valve) is leaking. Make repairs or replace equipment as required. (Also see section 6.C)
  - c. When test is complete continue to step 6.
6. Close the priming level test valve.
7. Close the ½" (15 mm) NPT anti-flood isolation valve\*\*.

**NOTE: AIR WILL CONTINUE TO FLOW FROM THE ACCELERATOR AFTER IT HAS OPERATED UNTIL STEP 8 IS PERFORMED.**

8. Loosen (use the appropriate wrench), and remove the accelerator air gauge to release pressure from the upper chamber of the accelerator, allowing it to reset.
9. Re-install, and tighten (use the appropriate wrench) the accelerator air gauge.
10. Allow pressure to be restored to the dry pipe system and accelerator.
11. When air pressure on the accelerator air gauge equals the system set pressure, verify that the intermediate chamber of the dry valve is free of water. No water should flow from the drip check when the plunger is pushed.
12. Open and secure the ½" (15 mm) NPT anti-flood isolation valve\*\*.
13. When testing is complete return the system being tested to service. Perform steps 10 through 16 of Placing the Accelerator in Service paragraph 4.D.I.

#### II. Non-Flow Accelerator Test On Pneumatic Release Systems

Semi-annual testing of accelerators is recommended. Conduct Non-Flow Test when Full Flow Test is not required.

1. Notify the Authority Having Jurisdiction and those in the area affected, by the test.
2. Close the water supply main control valve to prevent unwanted operation of the system.
3. Open the necessary drain valve to relieve pressure from the inlet chamber of valve being controlled by the pneumatic release system.
4. Operate a detector or open a test valve to relieve pressure from the pneumatic release system, (simulating operation of the detection system) while observing the vent in the bottom of the accelerator.  
A burst of air from the vent in the bottom of the accelerator indicates that the accelerator has operated. No water should flow from the vent.  
A spurt of water from the vent may indicate that the air supply is not being dried adequately.
5. When testing is complete, perform steps 1 through 6 of Placing the Accelerator in Service paragraph 4.D.II.

#### III. Flow Testing On Dry Valves

Partial Flow Tests are conducted with the water supply Main Control Valve (supplying the dry valve being tested) partially closed to minimize the amount of water entering the system during the test. The water supply control valve is closed immediately after the dry valve operates to keep water from filling the system piping. A Partial Flow Test may verify operation of equipment and devices, but does not simulate operation of the system in fire conditions.

Full Flow Tests are conducted with the water supply Main Control Valve fully open. The dry valve is operated by opening the system Test Valve to simulate the opening of a sprinkler in fire conditions.

Conduct a Partial Flow Test during warm weather at least annually. Conduct a Full Flow Test during warm weather at least once every three years. More frequent testing may be required by the Authority Having Jurisdiction:

1. Notify the Authority Having Jurisdiction and those in the area affected by the test.

**CAUTION: PERFORMING STEP 2 OF THIS TEST PROCEDURE WILL CAUSE THE DRY VALVE TO OPEN. THE ACCELERATOR WILL OPERATE, THE DRY VALVE WILL TRIP AND WATER WILL ENTER THE SPRINKLER SYSTEM PIPING.**

2. Operate the accelerator by performing the steps indicated below for the test procedure desired.
  - a. For Full Flow Test:
    - i. With the water supply main control valve open, fully open the main drain. Allow the flow to continue long enough to flush any foreign material from the water supply piping.
    - ii. Close the Main Drain.
    - iii. Open the system Test Valve to simulate operation of a sprinkler.
    - iv. Close the water supply main control valve after the accelerator operates and test is complete. Proceed to step 3.
  - b. For Partial Flow Test:



## TECHNICAL DATA

## ACCELERATOR MODEL E-1

The Viking Corporation, 210 N Industrial Park Road, Hastings MI 49058

Telephone: 269-945-9501 Technical Services 877-384-5464 Fax: 269-945-4495 Email: techsvcs@vikingcorp.com

- i. With the water supply main control valve fully open, open the Main Drain. Allow the full flow to continue long enough to flush any foreign material from the water supply piping.
  - ii. With the Main Drain fully open, slowly close the water supply main control valve until flow from the Main Drain is reduced as far as possible while maintaining the full flow from the Main Drain.
  - iii. Close the Main Drain.
  - iv. Fully open the Priming Level Test Valve to simulate operation of a sprinkler.
  - v. Close the water supply main control valve IMMEDIATELY after the accelerator operates and the dry valve trips.
3. Record operating times as required by the Authority Having Jurisdiction.
  4. When operation time testing is complete, return the system being tested to service. Perform steps 1 through 16 of Placing the Accelerator in Service paragraph 4.D.I and Technical Data for the dry valve and equipment used.

### IV. Flow Testing on Pneumatic Release Systems

1. Notify the Authority Having Jurisdiction and those in the area affected, by the test.
2. Perform PERIODIC NON-FLOW TEST to verify proper operation of the Accelerator. Refer to paragraph 6.B.II.

**CAUTION: PERFORMING STEP 3 OF THIS TEST PROCEDURE WILL CAUSE THE VALVE CONTROLLED BY THE PNEUMATIC RELEASE SYSTEM TO OPEN. WATER WILL ENTER THE SYSTEM PIPING.**

3. Operate a detector or open a Test Valve to relieve pressure from the Pneumatic Release system, (simulating operation of the detection system).
4. When operation testing is complete return the system being tested to service. Refer to Technical Data for the system used:
  - Close the water supply Main Control Valve.
  - Open all Main Drains and Auxiliary drains. Allow enough time to completely drain the system.
  - Close all drains opened in step "b" above.
  - Close the Detector or Test Valve opened in step 3 above.
  - Perform steps 1 through 6 of Placing the Accelerator in Service paragraph 4.D.II.

### C. MAINTENANCE

**NOTE: FOR ANTI-FLOOD DEVICE MAINTENANCE, REFER TO THE TECHNICAL DATA PAGE DESCRIBING THE ANTI-FLOOD DEVICE USED.**

#### I. On Dry Valves

**To remove a Model E-1 Accelerator from the trim of the dry valve for inspection and/or maintenance.**

1. Close the water supply main control valve and open the Main Drain (located on the inlet of the dry valve), placing the system out of service.
2. For UL and ULC Listing, and/or FM systems equipped with the Model B-1 external Anti-flood Device, proceed to step 3.
3. Close the ½" NPT Anti-flood Isolation Valve.
4. Turn the Air Supply to the accelerator OFF. Remove the pressure from the piping in which the accelerator is installed by either:
  - a. Temporarily loosening the pipe union between the accelerator and the spring loaded Check Valve located downstream of the accelerator, or,
  - b. Temporarily opening the Priming Level Test Valve in the trim of the Dry Valve (until the accelerator operates).
5. Loosen the accelerator air gauge to vent air pressure trapped in the upper chamber.
6. Remove the accelerator and, if necessary, the Anti-flood Device from the system. See Trim Chart for the accelerator and the dry valve used.
7. Refer to Accelerator Disassembly paragraph 6.C.III.

**NOTE: AIR SUPPLY MAY BE RESTORED TO PLACE THE DRY SYSTEM BACK IN SERVICE WITHOUT THE ACCELERATOR. PLUG AND/ OR CAP OPENINGS CREATED IN TRIM PIPING BY REMOVAL OF THE ACCELERATOR. NOTIFY ALL AUTHORITIES HAVING JURISDICTION IF THE DRY SYSTEM IS TEMPORARILY RETURNED TO SERVICE WITH THE ACCELERATOR REMOVED. TO PLACE THE DRY SYSTEM IN SERVICE WITHOUT THE ACCELERATOR, REFER TO THE TECHNICAL DATA FOR THE DRY VALVE USED.**

#### II. On Pneumatic Release Systems

**For installations with a ½" (15 mm) NPT Ball Valve between the accelerator and the point of connection to the Pneumatic Release System:**

The accelerator may be removed without taking the Pneumatic Release System out of service.

1. Close the ½" (15 mm) ball valve located between the accelerator and the pneumatic release system.
2. Loosen the accelerator air gauge to vent the trapped air pressure from the accelerator.
3. Remove the ½" (15 mm) NPT plug from the plugged opening in the base of the accelerator.
4. Proceed with steps 5 through 7 below.

**For Installations without a ½" (15 mm) NPT ball valve between the accelerator and the point of connection to the**



## TECHNICAL DATA

## ACCELERATOR MODEL E-1

The Viking Corporation, 210 N Industrial Park Road, Hastings MI 49058

Telephone: 269-945-9501 Technical Services 877-384-5464 Fax: 269-945-4495 Email: techsvcs@vikingcorp.com

### Pneumatic Release System:

The Pneumatic Release System must be placed out of service and pressure must be released from the detection system to remove the accelerator for inspection and /or maintenance.

1. Close the water supply main control valve supplying the Valve controlled by the Pneumatic Release system, placing the system out of service.
2. Turn OFF air supply to the accelerator.
3. Remove the pressure from the piping in which the accelerator is installed.
4. Loosen the accelerator air gauge to vent air pressure trapped in the upper chamber.
5. Remove the accelerator from the system.
6. Plug or cap the opening created by removing the accelerator.
7. Refer to Accelerator Disassembly paragraph 6.C.III.

**NOTE: THE AIR SUPPLY MAY BE RESTORED TO PLACE THE PNEUMATIC RELEASE SYSTEM BACK IN SERVICE WITHOUT THE ACCELERATOR. NOTIFY ALL AUTHORITIES HAVING JURISDICTION IF THE SYSTEM IS TEMPORARILY RETURNED TO SERVICE WITH THE ACCELERATOR REMOVED. TO PLACE THE SYSTEM IN SERVICE WITHOUT THE ACCELERATOR, REFER TO TECHNICAL DATA FOR PNEUMATIC RELEASE OPERATION OF THE SYSTEM USED.**

### III. Disassembly (refer to Figure 1)

1. To inspect and/or remove Cover Diaphragm Assembly (13), or Actuator Rod (10) with Spring (11):
  - a. Remove the four cross-head screws (16a) from cover (15) and remove cover (15) from Housing (8).
  - b. Remove Cover Diaphragm Assembly (13) for inspection. Blow air through filters and orifice. Replace the assembly if unit is plugged or damaged. Do not attempt to wash or clean the filters or orifice. Water may cause them to become plugged, requiring replacement of the assembly.
  - c. Remove actuator rod (10) with spring (11) for inspection and cleaning. Replace the actuator rod (10) if it is pitted, corroded or damaged.

**NOTE: REPLACE BOTH U-CUPS (4), WHENEVER ACTUATOR ROD (10) IS REPLACED. SEE STEP 2-C.**

2. To inspect and/or clean seat (2) or inspect and/or remove Clapper Diaphragm (3):
  - a. Remove four cross-head screws (16b) from base (1) and separate Housing (8) from Base (1).
  - b. Remove Clapper Diaphragm (3) and Housing Spring (6) for inspection.
  - c. To remove the Lower U-cup retainer (5b), and Lower U-Cup (4b) for inspection, carefully push them out of their seat from the opposite side of the clapper diaphragm (3). Upper U-cup retainer (5a) and U-Cup (4a) may be removed by pushing them out of their seat from the opposite side of the Housing Insert (9). Replace U-Cups if damaged, and whenever actuator rod (10) is replaced.

**CAUTION: USE ONLY A BLUNT TOOL, NOT MORE THAN 1/8" (3,2 MM) DIAMETER, TO PUSH U-CUPS FROM THEIR SEATS.**

- d. Inspect housing (8) and clean orifices as required. If necessary, remove screen filter (7) from housing (8) for cleaning. Replace the screen filter (7) if it is plugged or damaged.
- e. Inspect seat (2). If contamination is detected, wipe clean. If the seat is damaged, remove the damaged seat by turning it counterclockwise, threading it out of Base (1). A 7/8" socket wrench is required.

### IV. Reassembly (refer to Figure 1)

1. To re-install seat (2), reverse DISASSEMBLY step 2 e.
2. To re-install Clapper Diaphragm (3), reverse DISASSEMBLY steps 2 a-c as required. Apply lithium grease to U-cups and U-cup retainers. Verify that locating pin and screen filter holes are properly aligned.
3. To re-install Cover Diaphragm (13), reverse DISASSEMBLY steps 1 a-c. Hold Actuator Rod (10) down so Retaining Ring (12) is flush with top of Housing Insert (9) when installing Cover Diaphragm Assembly (13).
4. Perform steps described in INSTALLATION paragraphs 4.A and/or 4.B and 4.C as required to re-install the accelerator.
5. Refer to PLACING ACCELERATOR IN SERVICE paragraph 4.D.I and/or 4.D.II and technical data for the system used.
6. Verify that the water supply main control valve is open and all other valves are in their normal operating position.
7. Perform flow test and/or non-flow test (as appropriate) to verify proper operation of the accelerator. Refer to PERIODIC NON-FLOW TEST paragraph 11-B.1 and/or PERIODIC FLOW TEST paragraph 11-B.2.

## 7. AVAILABILITY

The Viking Model E-1 Accelerator and accessories are available through a network of Domestic, Canadian, and International Distributors. See the Viking Corp. Web site for your closest distributor or contact The Viking Corporation.

## 8. GUARANTEES

For details of warranty, refer to Viking's current list price schedule or contact Viking directly.



# TECHNICAL DATA

## ACCELERATOR MODEL E-1

The Viking Corporation, 210 N Industrial Park Road, Hastings MI 49058

Telephone: 269-945-9501 Technical Services 877-384-5464 Fax: 269-945-4495 Email: techsvcs@vikingcorp.com

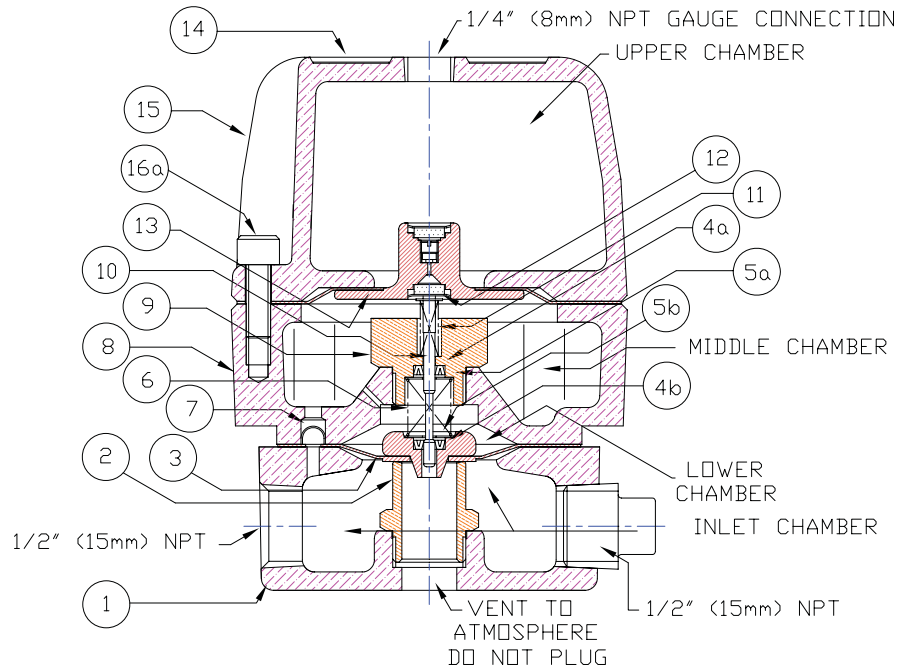
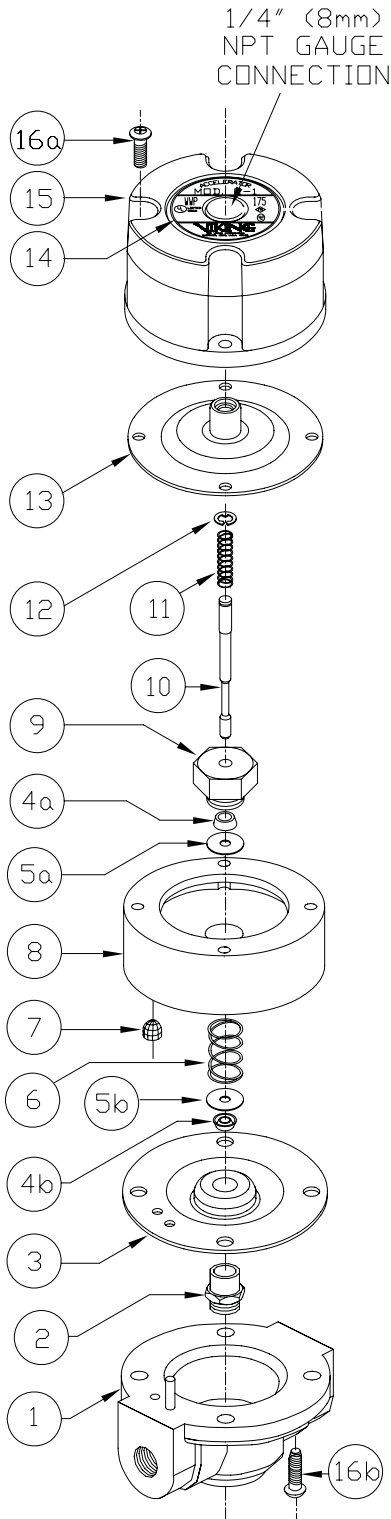

ITEM NO.	PART NUMBER	DESCRIPTION	MATERIAL	NO. REQ'D
1	--	Base	Brass: UNS-C84400	1
2	*	Seat	Brass: UNS-C36000	1
3	*	Clapper Diaphragm	Polyethersulfone/EPDM	1
4a & 4b	*	U-Cup	Buna-N ASTM D2000	2
5a & 5b	*	U-Cup Retainer	Stainless Steel UNS-S30200/S30400	2
6	*	Housing Spring	Stainless Steel: UNS-S30200	1
7	*	Screen Filter	Stainless Steel: UNS-S30400 40 x 36 mesh screen	1
8	--	Housing	Brass: UNS-C84400	1
9	*	Housing Insert	Brass: UNS-C36000	1
10	*	Actuator Rod	Emralon Coated Brass: UNS-C36000	1
11	*	Actuator Rod Spring	Stainless Steel: UNS-S30200	1
12	*	Retaining Ring	Stainless Steel: UNS-S15700	1
13	05480B	Cover Diaphragm Assembly	Dacon Reinforced Nitrile Rubber/ Polyethersulfone	1
14	--	Cover Label	0.012 (.30mm) Aluminum	1
15	--	Cover	Brass: UNS-C84400	1
16a & 16b	*	Screw; Round Head 1/4-20 x 3/4 (19mm)	Zinc Plated Steel	8
17	*	Lithium Grease	Lithium Grease	3/8 oz.
18	05472A	Locating Pin	Stainless Steel	1

-- Indicates replacement part not available  
 \* Indicates replacement part only available in a Sub-Assembly, as indicated below.

**SUB-ASSEMBLY**

2-7, 9-12, 16-17	12503	Repair Kit - Includes Air Gauge
------------------------	-------	---------------------------------

**Figure 1 - Replacement Parts**