



TECHNICAL DATA

**DELUGE VALVE
MODEL E-1
ANGLE STYLE
2" (DN50)**

The Viking Corporation, 210 N Industrial Park Road, Hastings MI 49058

Telephone: 269-945-9501 Technical Services 877-384-5464 Fax: 269-945-4495 Email: techsvcs@vikingcorp.com

1. DESCRIPTION

The Viking 2" (DN50) Model E-1 Deluge Valve is a quick-opening, differential diaphragm, flood valve with one moving part. The deluge valve is used to control water flow in deluge and preaction sprinkler systems. The valve is held closed by system water pressure trapped in the priming chamber, keeping the outlet chamber and system piping dry. In fire conditions, when the releasing system operates, pressure is released from the priming chamber. The deluge valve clapper opens to allow water to flow into the system piping.

Features

1. Field replaceable diaphragm and seat rubbers.
2. Designed for installation in any position.
3. Designed to be reset without opening the valve.
4. Approved with hydraulic, pneumatic, and/or electric release systems.



2. LISTINGS AND APPROVALS:

For 250 PSI (17.2 bar) WWP

U.L. Listed - Guide No. VLFT & VLJH

C-UL Listed - Guide No. VLFT7

FM Approved - Deluge Sprinkler Systems, Preaction Sprinkler Systems, Refrigerated Area Sprinkler Systems, On-Off Multi-Cycle Sprinkler Systems

American Bureau of Shipping (ABS) - Certificate No. 03-HS405911B-PDA

For 175 PSI (12.1 bar) WWP

New York City Board of Standard and Appeals - Calendar Number 219-76-SA

LPCB

VdS - G 4920053

CE - Pressure Equipment Directive 97/23/EC

3. TECHNICAL DATA

Specifications:

Maximum Working Water Pressure - 250 PSI

90 Degree Pattern (inlet to outlet)

Connections: 2" female NPT inlet and outlet

Factory tested to 500 psi (34.5 bar)

Valve differential: over 2:1 (priming chamber to inlet chamber)

Priming chamber supply restriction (required): 0.062" (1,6 mm)

Color of Valve: Red

Cv Factor: 93

Friction loss: 13 ft. (4,0 m) Expressed in equivalent length of Schedule 40 pipe based on Hazen & Williams formula. C = 120

Material Standards:

Refer to Figure 3

Ordering Information:

Order Part Number 05852C

Available since 1985

Shipping weight: 35 lbs. (16 kg)

Accessories:

Refer to Current VIKING PRICE LIST for Part Numbers.

1. A Conventional trim package for use with the 2" (DN50) Model E-1 Deluge Valve. The trim package includes the VALVE ACCESSORY PACKAGE and the fittings and nipples shown on the Viking Deluge Valve Conventional Trim Charts for the valve used. Trim Charts are provided in trim packages and the Viking Engineering and Design Data book. For optional factory assembled "modular" trim packages, refer to the Viking list price schedule or contact the manufacturer.
2. A Deluge VALVE ACCESSORY PACKAGE includes required trim components. This package is needed when Viking Trim Packages are not used.
3. Auxiliary Components are required for specific valve functions. For complete operating trim requirements, refer to system data for the system used. System data is provided in the Viking Engineering and Design Data book.

Additional accessories are available and may be required for system operation or supervision. Refer to the system description and

Viking Technical Data may be found on
The Viking Corporation's Web site at
<http://www.vikinggroupinc.com>.
The Web site may include a more recent
edition of this Technical Data Page.



TECHNICAL DATA

**DELUGE VALVE
MODEL E-1
ANGLE STYLE
2" (DN50)**

The Viking Corporation, 210 N Industrial Park Road, Hastings MI 49058

Telephone: 269-945-9501 Technical Services 877-384-5464 Fax: 269-945-4495 Email: techsvcs@vikingcorp.com

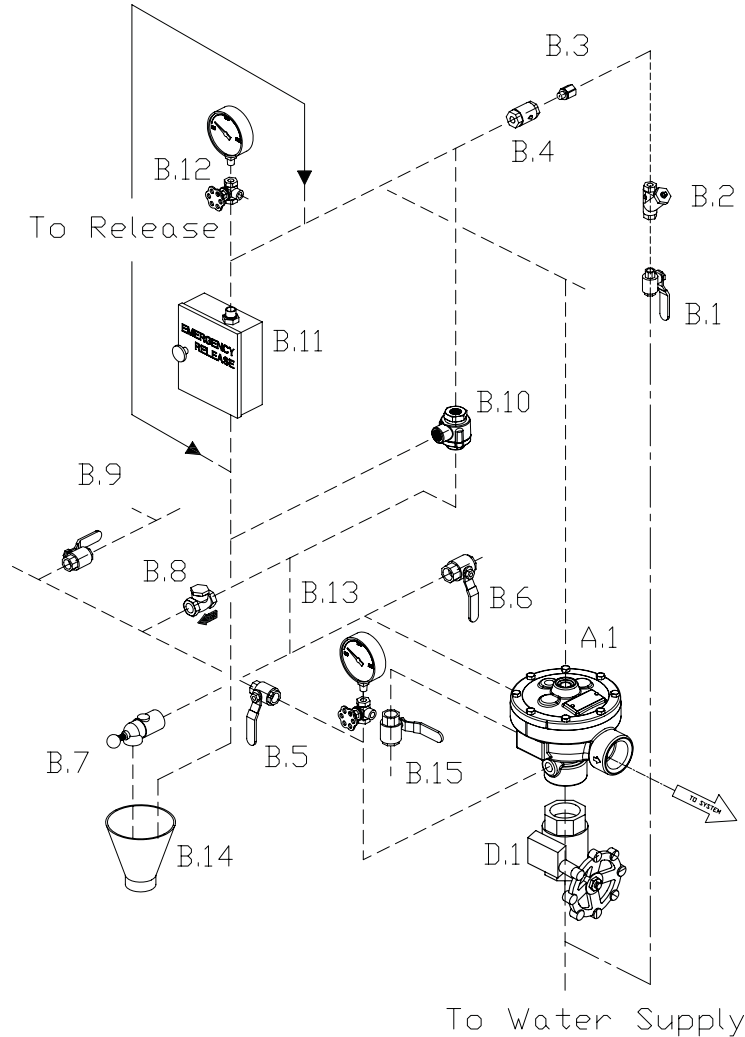

----- Dashed lines indicate Nipples and Fittings included with Trim
 - - - - - Phantom lines indicate Piping required but not included with Trim

Figure 1 - Trim Components

- | | | | |
|-----|---|------|---|
| A.1 | Deluge Valve | B.9 | Alarm Shut Off Valve (Normally Open) |
| B.1 | Priming Valve (Normally Open) | B.10 | Pressure Operated Relief Valve (PORV) |
| B.2 | Strainer | B.11 | Emergency Release |
| B.3 | 1/16" Restricted Orifice | B.12 | Priming Pressure Water Gauge and Valve |
| B.4 | Spring Loaded Check Valve | B.13 | Water Supply Pressure Water Gauge and Valve |
| B.5 | Alarm Test Valve (Normally Closed) | B.14 | Drain Cup |
| B.6 | Auxiliary Drain Valve (Normally Closed) | B.15 | Flow Test Valve (Normally Closed) |
| B.7 | Drip Check Valve | D.1 | Water Supply Control Valve |
| B.8 | Drain Check Valve | | |

	<h1 style="margin: 0;">TECHNICAL DATA</h1>	<p>DELUGE VALVE MODEL E-1 ANGLE STYLE 2" (DN50)</p>
---	--	--

The Viking Corporation, 210 N Industrial Park Road, Hastings MI 49058

Telephone: 269-945-9501 Technical Services 877-384-5464 Fax: 269-945-4495 Email: techsvcs@vikingcorp.com
 technical data for complete operating trim requirements for the system used.

4. INSTALLATION (Refer to Figure 1)

A. General Instruction

1. Viking 2" (DN50) Model E-1 Deluge Valves may be installed in any position.
 - a. Minor modification to trim may be required to facilitate drainage from the outlet chamber of the Deluge Valve (consult manufacturer).
 - b. Certain trim devices may require the valve to be installed vertically. (Refer to system data for the system used.)
2. The valve must be installed in an area not subject to freezing temperatures or physical damage.
3. The valve must be trimmed according to current Viking Trim Charts and appropriate instructions for the system used. Trim Charts are printed in the Viking Engineering and Design Data book, and are provided with trim packages.

TRIM NOTE: (REFER ALSO TO SYSTEM DATA AND/OR TRIM CHART) DISCHARGE PIPING FROM THE AUXILIARY DRAIN VALVE, THE FLOW TEST VALVE, AND ALL SYSTEM DRAINS SHOULD BE KEPT SEPARATE. DO NOT CONNECT THE OUTLET OF THE DRIP CHECK TO ANY OTHER DRAIN. EXCEPTION: VIKING TOTALPAC SYSTEMS ARE MANUFACTURED WITH A SPECIFIC ARRANGEMENT OF INTERCONNECTED DRAIN PIPING TESTED AT THE FACTORY.

4. The priming line must be connected upstream of the system water supply main control valve or to a constant source of water at a pressure equal to the system water supply.
5. After the deluge valve is set, operation of the deluge valve requires the release of priming water from the priming chamber. This may be by automatic or manual operation of the release system. Viking deluge valves are compatible with hydraulic, pneumatic, and electric release systems. For specific trim arrangements, refer to Trim Charts and System Data describing the system being installed. Trim Charts are printed in the Viking Engineering and Design Data book, and are provided with trim packages. System Data sheets are printed in the Viking Engineering and Design Data book.
 - a. Hydraulic Release Systems - See Figure 2 for the maximum allowable elevation of hydraulic release piping above the deluge valve. If the maximum height of hydraulic release piping exceeds the limits shown in Figure 2, use pneumatic or electric

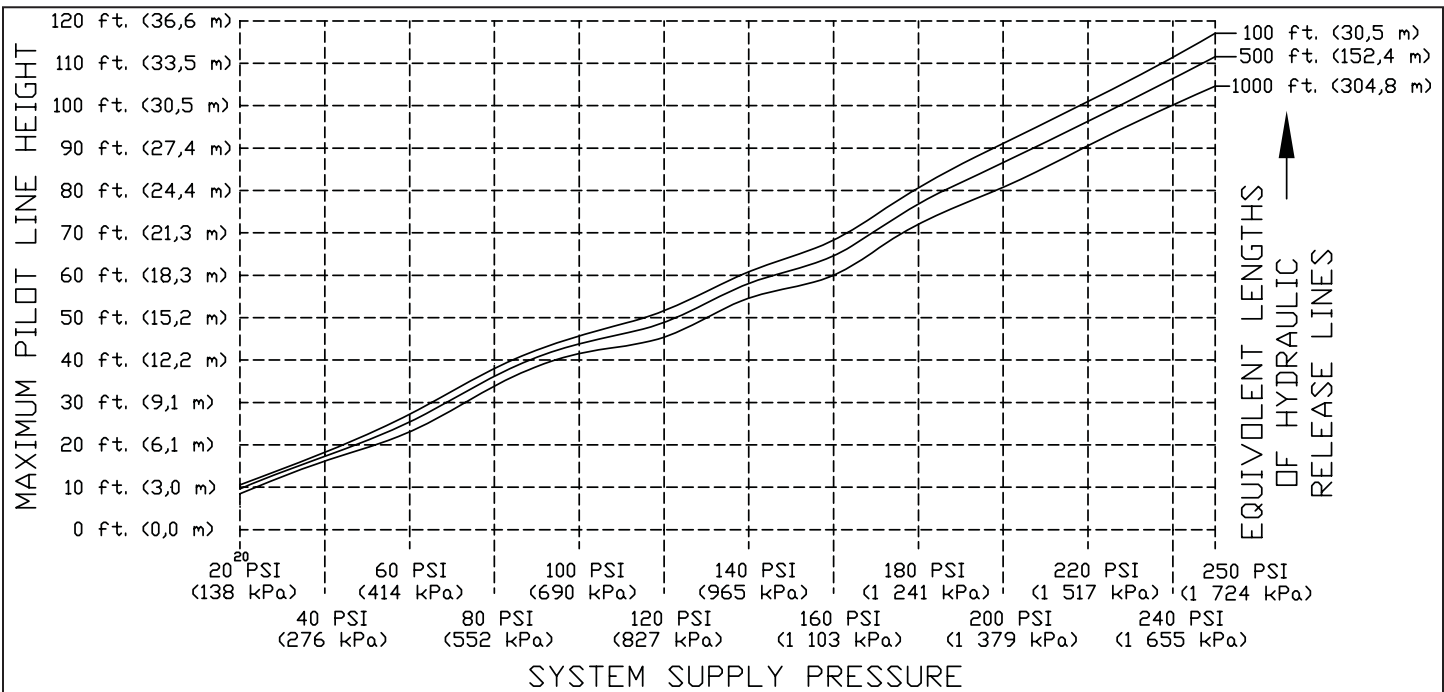

Figure 2
Maximum Allowable Pilot Heights for Select Equivalent Lengths of Hydraulic Release Piping
For 2" (DN50) Model E Deluge Valves with 1/16" (1,6 mm) Restricted Orifice

Graph is based on 1/2" (15 mm) pilot sprinklers installed on 1/2" (15 mm) Schedule 40 galvanized release system piping.
 If the maximum height of hydraulic release piping exceeds the limits shown on the graph, use pneumatic or electric release system.



TECHNICAL DATA

**DELUGE VALVE
MODEL E-1
ANGLE STYLE
2" (DN50)**

The Viking Corporation, 210 N Industrial Park Road, Hastings MI 49058

Telephone: 269-945-9501 Technical Services 877-384-5464 Fax: 269-945-4495 Email: techsvcs@vikingcorp.com

release system.

- b. Pneumatic Release Systems - A Viking Pneumatic Actuator is required between the release system connection provided on deluge valve trim and pneumatic release system piping.
- c. Electric Release - Solenoid Valves, System Control Panels, and Electrical Detectors must be compatible. Consult appropriate listing and/or approval guides.

CAUTION: OPERATION OF VIKING DELUGE VALVES BY PRESSURIZING THE PRIMING CHAMBER WITH AIR PRESSURE OR ANY OTHER PRESSURIZED GAS IS NOT RECOMMENDED OR APPROVED.

B. Placing the Valve in Service (Refer to Figure 1 and/or appropriate Trim Charts and System Data for the system used.)

For deluge valves equipped with Conventional Deluge Valve Trim, follow steps 1 through 10 (and 11 & 12 if applicable) below.

1. Verify:
 - a. The system Main Water Supply Control Valve (D.1) is closed and the Deluge Valve is trimmed according to current Viking Trim Charts and schematic drawings for the system used.
 - b. The system has been properly drained.
 - c. Auxiliary Drain (B.6) is open.
 - d. The Emergency Release (B.11) is closed.
 - e. The system water supply piping is pressurized up to the closed Main Water Supply Control Valve (D.1) and the priming line is pressurized up to the closed Priming Valve (B.1).
2. For Systems equipped with:
 - a. Hydraulic Release Systems:
 - i. Verify that all releasing devices are set and that any Inspector's Test Valve and/or auxiliary drain valves are closed.
 - ii. Open Priming Valve (B.1).
 - iii. Proceed to step 3.
 - b. Pneumatic Release Systems:
 - i. Set the release system.
 - ii. Open Priming Valve (B.1).
 - iii. Proceed to Step 3.
 - c. Electric Release Systems:
 - i. Open Priming Valve (B.1).
 - ii. Set the electric release system.
 - iii. Proceed to Step 3.
3. Open Flow Test Valve (B.15).
4. Partially open Main Water Supply Control Valve (D.1).
5. When full flow develops from the Flow Test Valve (B.15), close the Flow Test Valve. Verify that there is no flow from the open Auxiliary Drain (B.6).
6. Close Auxiliary Drain (B.6).
7. Fully open and secure the Main Water Supply Control Valve (D.1).
8. Verify that the Alarm Shut-off Valve (B.9) is open and that all other valves are in their normal operating position.
9. Depress the plunger of Drip Check (B.7). No water should flow from the Drip Check when the plunger is pushed.
10. Check for and repair all leaks.
11. On new installations, systems that have been placed out of service, or where new equipment has been installed, trip test the system to verify that all equipment functions properly. Refer to Tests paragraph 6.II.C - ANNUAL.

CAUTION: PERFORMING A TRIP TEST RESULTS IN OPERATION OF THE DELUGE VALVE. WATER WILL FLOW INTO THE SPRINKLER PIPING. TAKE NECESSARY PRECAUTIONS TO PREVENT DAMAGE.

12. After completing a trip test, perform SEMI-ANNUAL maintenance.

C. Valve Removed From Service

NOTE: WHEN A VALVE HAS BEEN REMOVED FROM SERVICE AND IS SUBJECT TO FREEZING OR WILL BE OUT OF SERVICE FOR AN EXTENDED PERIOD OF TIME, ALL WATER MUST BE REMOVED FROM THE PRIMING CHAMBER, TRIM PIPING, WATER SUPPLY PIPING, AND OTHER TRAPPED AREAS.

5. OPERATION (Refer to Figures 1 & 3)

The Viking 2" (DN50) Model E-1 Deluge Valve has an inlet chamber, an outlet chamber and a priming chamber. The inlet chamber and outlet chamber are separated from the priming chamber by the clapper (6) and diaphragm (2).

In the set condition:

System pressure is supplied to the priming chamber through a restricted priming line (trim) equipped with a check valve. System water supply pressure trapped in the priming chamber holds the clapper (6) on seat (9) due to area differential design. Clapper (6) separates



TECHNICAL DATA

**DELUGE VALVE
MODEL E-1
ANGLE STYLE
2" (DN50)**

The Viking Corporation, 210 N Industrial Park Road, Hastings MI 49058

Telephone: 269-945-9501 Technical Services 877-384-5464 Fax: 269-945-4495 Email: techsvcs@vikingcorp.com

the inlet chamber from the outlet chamber, keeping the outlet chamber and system piping dry.

In fire conditions:

When the release system operates, pressure is released from the priming chamber faster than it is supplied through the restricted priming line. Water supply pressure in the inlet chamber forces the clapper (6) off seat (9), allowing water to flow through the outlet and into the system and alarm devices.

For Deluge Valves equipped with Conventional Trim:

When the Deluge Valve operates, the sensing end of the PORV (B.10) is pressurized, causing the PORV (B.10) to operate. When the PORV (B.10) operates, it continually vents the priming chamber to prevent the deluge valve from resetting even if the open releasing devices close. The Deluge Valve can only be reset after the system is taken out of service, and the outlet chamber of the deluge valve and associated trim piping is depressurized and drained.

6. INSPECTIONS, TESTS AND MAINTENANCE (Refer to Figure 1).

I. Inspection

It is imperative that the system be inspected and tested on a regular basis. The frequency of the inspections may vary due to contaminated water supplies, corrosive water supplies, or corrosive atmospheres. Also, the alarm devices, detection systems, or other connected trim may require a more frequent schedule. For minimum maintenance and inspection requirements, refer to the National Fire Protection Association's pamphlet NFPA 25 that describes care and maintenance of sprinkler systems. In addition, the Authority Having Jurisdiction may have additional maintenance, testing, and inspection requirements that must be followed. The following recommendations are minimum requirements. (For additional information, refer to Viking Trim Charts and System Data describing systems with the release system used.)

A. Weekly:

Weekly visual inspection of the Viking Deluge Valve is recommended.

1. Verify that the Main Water Supply Control Valve (D.1) is open and that all other valves are in their normal operating position and appropriately secured. For normal operating position, refer to Figure 1 and/or Trim Charts and System Data for the system used.
2. Check for signs of mechanical damage, leakage, and/or corrosive activity. If detected, perform maintenance as required. If necessary, replace the device.
3. Verify that the valve and trim are adequately heated and protected from freezing and physical damage.

II. Tests

Quarterly testing of water flow alarms and performance of a Main Drain Test is recommended and may be required by the Authority Having Jurisdiction.

A. Quarterly Water Flow Alarm Test

1. Notify the Authority Having Jurisdiction and those in the area affected by the test.
2. To test the local electric alarm (if provided) and/or mechanical water motor alarm (if provided), OPEN the alarm test valve (B.5) in the deluge valve trim.
 - a. Electric alarm pressure switches (if provided) should activate.
 - b. Electric local alarms should be audible.
 - c. The local water motor gong should be audible.
 - d. If equipped with remote station alarm signaling devices, verify that alarm signals were received.
3. When testing is complete, CLOSE the alarm test valve (B.5).
4. Verify:
 - a. All local alarms stop sounding and alarm panels (if provided) reset.
 - b. All remote station alarms reset.
 - c. Supply piping to water motor alarm properly drains.
5. Verify that the alarm shut-off valve (B.9) is OPEN, and the alarm test valve (B.5) is CLOSED.
6. Verify that the outlet chamber is free of water. No water should flow from the drip check when the plunger is pushed.
7. Notify the Authority Having Jurisdiction and those in the affected area that testing is complete.

B. Quarterly Main Drain Test

1. Notify the Authority Having Jurisdiction and those in the area affected by the test.
2. Record pressure reading from the water supply pressure gauge (B.13).
3. Verify that the outlet chamber of the Deluge Valve is free of water. No water should flow from the drip check (B.7) when the plunger is pushed.
4. Fully OPEN the Flow Test Valve (B.15).
5. When a full flow is developed from the Flow Test Valve (B.15), record the residual pressure from the water supply pressure gauge (B.13).
6. When the test is complete, SLOWLY CLOSE the Flow Test Valve (B.15).



TECHNICAL DATA

**DELUGE VALVE
MODEL E-1
ANGLE STYLE
2" (DN50)**

The Viking Corporation, 210 N Industrial Park Road, Hastings MI 49058

Telephone: 269-945-9501 Technical Services 877-384-5464 Fax: 269-945-4495 Email: techsvcs@vikingcorp.com

7. Compare test results with previous flow information. If deterioration of the water supply is detected, take appropriate steps to restore adequate water supply.
8. Verify:
 - a. Normal water supply pressure has been restored to the inlet chamber, the priming chamber, and the release system. The pressure on the priming chamber water pressure gauge should equal the system water supply pressure.
 - b. All alarm devices, and valves are secured in normal operating position. For normal operating position, refer to Figure 1 and/or Trim Charts and System Data for the system used.
9. Notify the Authority Having Jurisdiction that the test is complete. Record and/or provide notification of test results as required by the Authority Having Jurisdiction.

C. Annual Trip Test

CAUTION! PERFORMING THIS TEST RESULTS IN OPERATION OF THE DELUGE VALVE. WATER WILL FLOW INTO THE SPRINKLER PIPING AND FROM ANY OPEN SPRINKLERS AND/OR NOZZLES. TAKE NECESSARY PRECAUTIONS TO PREVENT DAMAGE.

1. Notify the Authority Having Jurisdiction and those in the area affected by the test.
2. Fully open the Flow Test Valve (B.15) to flush away any accumulation of foreign material.
3. Close the Flow Test Valve (B.15).
4. Trip the system by operating the release system. Allow a full flow to pass through the deluge valve. Water flow alarms should operate.
5. When test is complete:
 - a. Close the Main Water Supply Control Valve (D.1).
 - b. Close the Priming Valve (B.1).
 - c. Open the Auxiliary Drain Valve (B.6).
 - d. Open all system main drains and auxiliary drains. Allow the system to drain completely.
6. Perform SEMI-ANNUAL maintenance. Refer to paragraph 6.III.B SEMI-ANNUAL MAINTENANCE
7. Place the system in service. Refer to Item 4.B, INSTALLATION: PLACING THE VALVE IN SERVICE.

NOTE: DELUGE VALVES SUPPLIED BY BRACKISH WATER, SALT WATER, FOAM, FOAM/WATER SOLUTION, OR ANY OTHER CORROSIVE WATER SUPPLY SHOULD BE FLUSHED WITH GOOD QUALITY FRESH WATER BEFORE BEING RETURNED TO SERVICE.

8. Notify the Authority Having Jurisdiction that the test is complete. Record and/or provide notification of test results as required by the Authority Having Jurisdiction.

III. Maintenance (Refer to Figure 1)

NOTICE: THE OWNER IS RESPONSIBLE FOR MAINTAINING THE FIRE PROTECTION SYSTEM AND DEVICES IN PROPER OPERATING CONDITION. THE DELUGE VALVE MUST BE KEPT FROM FREEZING CONDITIONS AND PHYSICAL DAMAGE THAT COULD IMPAIR ITS OPERATION.

Where difficulty in performance is experienced, the valve manufacturer or his authorized representative shall be contacted if any field adjustment is to be made.

WARNING: ANY SYSTEM MAINTENANCE WHICH INVOLVES PLACING A CONTROL VALVE OR DETECTION SYSTEM OUT OF SERVICE MAY ELIMINATE THE FIRE PROTECTION CAPABILITIES OF THAT SYSTEM. PRIOR TO PROCEEDING, NOTIFY ALL AUTHORITIES HAVING JURISDICTION. CONSIDERATION SHOULD BE GIVEN TO EMPLOYMENT OF A FIRE PATROL IN THE AFFECTED AREAS.

A. After Each Operation:

1. Sprinkler systems that have been subjected to a fire must be returned to service as soon as possible. The entire system must be inspected for damage, and repaired or replaced as necessary.
2. Deluge valves and trim that have been subjected to brackish water, salt water, foam, foam/water solution, or any other corrosive water supply should be flushed with good quality fresh water before being returned to service.
3. Perform SEMI-ANNUAL maintenance after every operation.

B. Semi-Annual Maintenance:

1. Remove the system from service. (Refer to Deluge or Preaction System Data that describes systems with the release system used for additional information.)
 - a. Close the Main Water Supply Control Valve (D.1) and Priming Valve (B.1).
 - b. Open the Auxiliary Drain Valve (B.6).
 - c. Relieve pressure in the priming chamber by opening the Emergency Release Valve (B.11).
2. Inspect all trim for signs of corrosion and/or blockage. Clean and/or replace as required.
3. Clean and/or replace all strainer screens (including B.2).
4. Refer to Item 4.B, INSTALLATION: PLACING THE VALVE IN SERVICE.



TECHNICAL DATA

DELUGE VALVE
MODEL E-1
ANGLE STYLE
2" (DN50)

The Viking Corporation, 210 N Industrial Park Road, Hastings MI 49058

Telephone: 269-945-9501 Technical Services 877-384-5464 Fax: 269-945-4495 Email: techsvcs@vikingcorp.com

C. Every Fifth Year

1. Internal inspection of deluge valves is recommended every five years unless inspections and tests indicate more frequent internal inspections are required. Refer to DISASSEMBLY instructions provided below.
2. Internal inspection of strainers, and restricted orifices is recommended every five years unless inspections and tests indicate more frequent internal inspections are required.
3. Record and provide notification of inspection results as required by the Authority Having Jurisdiction.

D. Valve Disassembly

1. Remove the valve from service.
 - a. Close the Main Water Supply Control Valve (D.1) and Priming Valve (B.1).
 - b. Open the Auxiliary Drain Valve (B.6).
 - c. Release the pressure in the priming chamber by opening the Emergency Release Valve (B.11).
2. Disconnect and remove necessary trim from the cover and remove cap screws (7).
3. Lift cover (3) from body (1).
4. Remove clapper assembly (2, 4, 5, 6, 7, 8, and 10) by lifting it from body (1).
5. Inspect seat (9). If replacement is necessary, do not attempt to separate it from body (1). Seat (9) is not removable.
6. To replace the diaphragm rubber (2), remove the circle of screws (5). Remove clamp ring (4). Diaphragm rubber (2) can be removed.
7. To replace the seat rubber assembly (8), clapper assembly (2, 4, 5, 6, 7, 8, and 10) must be removed from the valve (see Step 3 above). Remove the circle of screws (10). Seat rubber assembly (8) can be removed.

NOTE: PRIOR TO INSTALLING A NEW DIAPHRAGM RUBBER (2) OR SEAT RUBBER (8), MAKE CERTAIN THAT ALL SURFACES ARE CLEAN AND FREE OF FOREIGN MATTER. THE SEAT (9) MUST BE SMOOTH AND FREE OF NICKS, BURRS OR INDENTATIONS.

NOTE: THE CLAPPER RUBBER MUST BE INSTALLED WITH THE RIDGE ON THE CLAPPER RUBBER FACING TOWARDS THE CLAPPER.

E. Valve Reassembly (Refer to Figure 3)

1. Prior to reassembly flush the valve of all foreign matter. The valve seat must be clean and free from all marks and scratches.
2. To reassemble, reverse disassembly procedure.

7. AVAILABILITY

The Viking Deluge Valve and accessories are available through a network of domestic, Canadian, and international distributors. For proper operation and approval, the valve must be trimmed in accordance with the current Viking Trim Chart for the valve used. Where difficulty in performance is experienced, verify that the valve is trimmed properly. Contact Viking or Viking's authorized representative before any field adjustments are made. See the Viking Corp. Web site for closest distributor or contact The Viking Corporation.

8. GUARANTEES

For details of warranty, refer to Viking's current price schedule or contact Viking directly.



TECHNICAL DATA

**DELUGE VALVE
MODEL E-1
ANGLE STYLE
2" (DN50)**

The Viking Corporation, 210 N Industrial Park Road, Hastings MI 49058

Telephone: 269-945-9501 Technical Services 877-384-5464 Fax: 269-945-4495 Email: techsvcs@vikingcorp.com

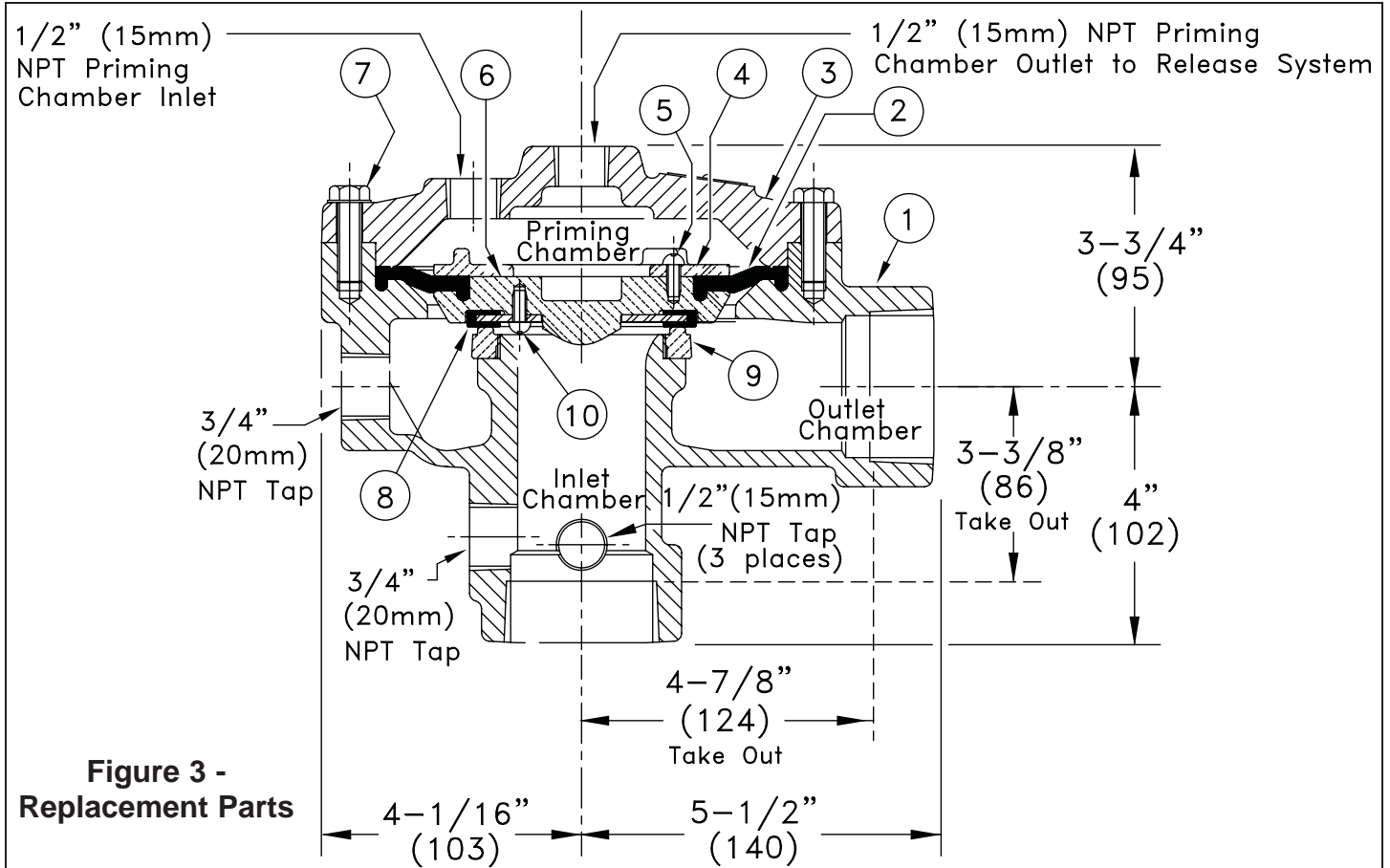

**Figure 3 -
Replacement Parts**

ITEM NO.	PART NUMBER	DESCRIPTION	MATERIAL	NO. REQ'D
1	--	Body	Ductile Iron 60-40-18	1
2	04223B	Diaphragm Rubber	EPDM	1
3	--	Cover	Ductile Iron 60-40-18	1
4	04224B	Clamp Ring	Bronze UNS-C84400	1
5	02494A	Screw, R.H. #10-24 x 1/2" lg.	Stainless Steel UNS-S30200	4
6	07046B	Clapper	Bronze UNS-C84400	1
7	05855A	Screw, H.H.C. 3/8-16 x 1-1/8" lg.	Steel	8
8	04225B	Seat Rubber Assembly	EPDM/Stainless Steel UNS-S30400	1
9	--	Seat	Bronze UNS-C84400	1
10	02494A	Screw, R.H. #10-24 x 1/2" lg.	Stainless Steel UNS-S30200	4

--Indicates replacement part not available

SUB-ASSEMBLY

2, 4-8, 10	13395	Clapper Assembly Kit		
------------	-------	----------------------	--	--