



TECHNICAL DATA

SPRINKLER ESCUTCHEONS

The Viking Corporation, 210 N Industrial Park Road, Hastings MI 49058

Telephone: 269-945-9501 Technical Services 877-384-5464 Fax: 269-945-4495 Email: techsvcs@vikingcorp.com

1. DESCRIPTION

Viking sprinkler escutcheons are ornamental plates used with 3/8" NPT (10 mm BSP)*, 1/2" NPT (15 mm BSP)**, and 3/4" NPT (20 mm BSP)*** frame-style pendent and sidewall† sprinklers. The escutcheons are installed between the sprinklers and the ceiling or wall for a pleasing appearance. They are available with several finish options to meet design requirements.

Viking recessed and adjustable escutcheons provide a low-profile decorative recessed sprinkler installation. The Micromatic® E-1 Recessed Escutcheon may be recessed up to 5/8" (16 mm). The Model G-1 Recessed Escutcheon allows residential horizontal sidewall sprinklers to be recessed up to 1/2" (12.7 mm). The Microfast® Model F-1 Adjustable Escutcheon has 1/2" (12.7 mm) total adjustment available, however, it is considered a surface-mounted escutcheon because it doesn't allow the fusible element of the sprinkler to be recessed behind the face of the wall or ceiling.

The two-piece design of Viking's recessed escutcheons and adjustable escutcheons allow installation and testing of the sprinklers prior to installing the ceiling or wall. Viking's Model E-1, F-1, and G-1 Escutcheons feature a slip-on design, while the Model E-2 escutcheons are threaded (outer cup threads onto the adapter).

The Viking recessed and adjustable escutcheons are made to allow for minor adjustments due to pipe or ceiling pitch. These escutcheons can be removed and reinstalled, allowing access above removable ceiling panels for servicing building equipment without shutting down the sprinkler system and removing the sprinkler.

Viking standard 1/8" (3 mm) style flat and 1" (25 mm) style raised surface-mounted escutcheons have a one-piece design.

*Micromatic® Model E-1 and E-2, and Microfast® Model F-1 Escutcheons with 3/8" NPT (10 mm BSP) adapters are for use with sprinkler VK032.

**Micromatic® Model E-1 and E-2, and Microfast® Model F-1 Escutcheons with 1/2" NPT adapters are for use with sprinklers VK003, VK004, VK007, VK008, VK015, VK023, VK102, VK104, VK110, VK112, VK116, VK134, VK202, VK206, VK302, VK303, VK304, VK305, VK317, VK319, VK329, VK331, VK333, VK342, VK344, VK352, VK430, VK432, VK434, VK435, VK436, VK437, VK438, VK439, VK440, VK442, VK444, VK446, VK448, VK450, VK452, VK453, VK458, VK460, VK468, VK600, VK604, VK605, VK610, and VK612.

***Micromatic® Model E-1 and E-2, and Microfast® Model F-1 Escutcheons with 3/4" NPT adapters are for use with sprinklers VK202, VK206, VK212, VK352, VK534, VK572, VK602, VK606, VK608, and VK630.

†Model G-1 Recessed Escutcheons are for use with residential horizontal sidewall sprinklers VK442, VK448, VK450, VK452, VK453, and VK460 for sloped ceiling applications with ceilings sloped up to a maximum of 8/12 (33.7°).



2. LISTINGS AND APPROVALS

Refer to the specific sprinkler technical data pages for sprinkler listings and approvals. Sprinklers must be specifically listed and/or approved for recessed installation. When using Viking Micromatic® Model E-1, E-2, and G-1 Recessed Escutcheons for recessed applications, refer to technical data describing the sprinkler model to be used to verify whether the sprinkler is listed and/or approved for recessed installations. NOTE: Viking's thread-on style Micromatic® Model E-2 Recessed Escutcheons carry the same listings and approvals as the slip-on style Micromatic® Model E-1 Recessed Escutcheons.

3. TECHNICAL DATA

Specifications:

A. Slip-on Style Micromatic® Model E-1 Recessed Escutcheons

Depth of Outer Cup: 1-1/16" (26.9 mm)
 Outside Diameter of Outer Cup: 3-1/16" (77.7 mm)
 Depth of Center Adapter Ring: 11/32" (8.7 mm) +/- 1/32" (0.8 mm)
 Adjustment Range: Flush to 5/8" (16 mm) recessed
 NOTE: Escutcheon adapter is stamped "Viking Model E-1".

B. Threaded Style Micromatic® Model E-2 Recessed Escutcheons

Depth of Outer Cup: 13/16" (20.6 mm)

Viking Technical Data may be found on
 The Viking Corporation's Web site at
<http://www.vikinggroupinc.com>.
 The Web site may include a more recent
 edition of this Technical Data Page.



TECHNICAL DATA

SPRINKLER ESCUTCHEONS

The Viking Corporation, 210 N Industrial Park Road, Hastings MI 49058

Telephone: 269-945-9501 Technical Services 877-384-5464 Fax: 269-945-4495 Email: techsvcs@vikingcorp.com

Outside Diameter of Outer Cup: 3-1/8" (79.4 mm)

Depth of Center Adapter Ring: 21/32" (16.6 mm)

Adjustment Range: 27/32" (21.4 mm) total adjustment with 1/2" (12.7 mm) maximum recess available. Note: Face of escutcheon adapter may extend up to 11/32" (8.7 mm) beyond edge of escutcheon cup.

NOTE: Escutcheon adapter is stamped "Viking Model E-2".

C. Microfast® Model F-1 Adjustable Escutcheons

Depth of Outer Cup: 1-1/16" (26.9 mm)

Outside Diameter of Outer Cup: 3-1/16" (77.7 mm)

Depth of Center Adapter Ring: 23/32" (18.3 mm)

Adjustment Range: 1/2" (12.7 mm) total adjustment with 1/4" (6.4 mm) maximum recess available. Note: The face of escutcheon adapter may extend up to 1/4" (6.4 mm) beyond the edge of the escutcheon cup.

NOTE: Escutcheon adapter is stamped "Viking Model F-1".

D. Slip-on Style Model G-1 Recessed Escutcheons (patent pending)

Depth of Outer Cup: 1-1/16" (26.9 mm)

Outside Diameter of Outer Cup: 4" (101.6 mm)

Depth of Center Adapter Ring: 1-7/16" (36.5 mm)

Adjustment Range: Up to 5/8" (16 mm) total adjustment available for use with ceilings sloped up to 8/12 (33.7°). May be recessed up to 1/2" (12.7 mm), depending on degree of slope. Note: The face of escutcheon adapter may extend up to 1/2" (12.7 mm) beyond the edge of the escutcheon cup.

NOTE: Escutcheon adapter is stamped "Viking Model G-1".

E. Expansion Plate (optional)

1. Base Part No. 12620 for use with Model E-1, E-2, and F-1 Escutcheons. May also be used with dry recessed sprinklers, dry standard adjustable sprinklers, and flat plate concealed sprinklers.
2. Base Part No. 13128 for use with Domed Concealed Sprinklers.

Outside Diameter: 5" (127 mm)

Inside Diameter: 2-3/16" (55.5 mm) for Part No. 12620, 2-15/32" (62.7 mm) for Part No. 13128.

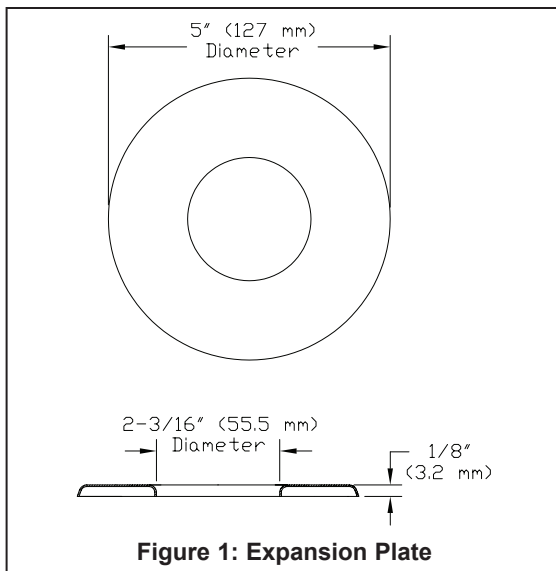

Figure 1: Expansion Plate

F. Standard Flat and Raised Surface-Mounted Escutcheons

Depth of Escutcheons: Flat: 1/8" (3.2 mm), Raised: 1" (25 mm)

Material Standards:

- A. Slip-on Style Micromatic® Model E-1 Recessed Escutcheons: Cold Rolled Steel UNS-G10080 or Stainless Steel UNS-S30400
- B. Threaded Style Micromatic® Model E-2 Recessed Escutcheons: 24 ga. (0.61 mm) thick 1010-1018 mild steel
- C. Model G-1 Recessed Escutcheons and Microfast® Model F-1 Adjustable Escutcheons: Cold Rolled Steel UNS-G10080
- D. Expansion Plate (optional): Cold Rolled Steel UNS-G10080



TECHNICAL DATA

SPRINKLER ESCUTCHEONS

The Viking Corporation, 210 N Industrial Park Road, Hastings MI 49058

Telephone: 269-945-9501 Technical Services 877-384-5464 Fax: 269-945-4495 Email: techsvcs@vikingcorp.com

E. Standard Flat and Raised Surface-Mounted Escutcheons:

Flat Style Part Numbers 01960A, 01015A, 02960A, and 05464A: Cold Rolled Steel UNS-G10080.

Flat Style Part Numbers 09488, 07526, and 09596*: Stainless Steel UNS-S43000

* These may also be special ordered and manufactured from Brass (non-magnetic material). Contact the manufacturer for more information.

Raised Style Part Numbers 01961B and 01016A: Brass UNS-C26000 or UNS-C26800.

Ordering Information: (Also refer to the current [Viking price list](#).)

Viking recessed and adjustable escutcheons are available as escutcheon packages (includes outer cup and adapter). The outer cups and adapters are also available to order separately as individual pieces for the 1/2" and 3/4" NPT (15 mm and 20 mm BSP) sizes. Order Viking escutcheons by adding the appropriate suffix for the finish to the base part number.

A. Microfast® Model F-1 Adjustable and Micromatic® Model E-1, E-2, and G-1 Recessed Escutcheons:

1. To order as an escutcheon package (includes outer cup and adapter), specify the appropriate package part number from Table 1.

2. To order individual outer cup or adapter separately for the 3/8", 1/2", and 3/4" NPT (10 mm, 15 mm, and 20 mm BSP) sizes, specify the appropriate part number for the individual piece from Table 1.

B. Standard Flat and Raised Surface-Mounted Escutcheons: Specify the flat or raised escutcheon part number from Table 1.

Finish Suffix: Bright Brass = B, Polished Chrome = F, White Polyester = M-/W, and Black Polyester = M-/B.

For example, the Micromatic® Model E-1 Recessed Escutcheon for 1/2" NPT sprinkler, Brass finish = Part No. 06419AB. The 1/2" Model E-1 Recessed Escutcheon is also available in Antique Brass, Brushed Copper, Brushed Chrome, and Brushed Brass as standard finishes.

NOTE: Sprinklers are not included and must be ordered separately.

4. INSTALLATION

A. If the proposed installation of Micromatic® Model E-1, E-2, or G-1 Recessed Escutcheons requires recessing any of the heat-sensitive operating element, some Authorities Having Jurisdiction may limit the use, depending on the occupancy classification. Refer to the Authority Having Jurisdiction prior to installation. The use of Microfast® sprinklers may also be limited due to occupancy and hazard. Refer to the Authority Having Jurisdiction prior to installation.

B. All escutcheon styles are made to thread onto the sprinkler head prior to installing the sprinkler into the fitting. The escutcheon must be attached to the sprinkler prior to applying pipe-joint compound or Teflon® tape to the sprinkler threads. NOTE: Sprinklers with protective caps or bulb shields must be contained within the caps or shields before applying pipe-joint compound or tape.

C. Refer to the appropriate sprinkler technical data page for additional warnings and installation instructions and then install the escutcheons according to the following sequence.

D. Microfast® Model F-1 Adjustable and Micromatic® Model E-1, E-2, and G-1 Recessed Escutcheons:

(Refer to Figures 2-5.)

Step 1: Install all piping and cut the sprinkler nipple so that the reducing coupling is at the desired location and centered in a minimum 2-5/16" (59 mm) to a maximum 2-1/2" (64 mm) diameter opening in the ceiling or wall for Model E-1, E-2, or F-1 Escutcheons, or 2-5/8" (66 mm) to 3-3/4" (95 mm) for Model G-1 Escutcheons.

Step 2: Secure the escutcheon adapter onto the sprinkler by hand turning the adapter clockwise onto the sprinkler threads. The face of the adapter should rest on the shoulder of the sprinkler wrench boss.

Step 3: Apply a small amount of pipe-joint compound or Teflon® tape to the external threads of the sprinkler only, taking care not to allow a build-up of compound in the sprinkler inlet. NOTE: Sprinklers with protective caps or bulb shields must be contained within the caps or shields before applying pipe-joint compound or tape.

Step 4: Install the sprinkler into the coupling using the special recessed sprinkler wrench only, taking care not to over-tighten or damage the sprinkler operating parts. DO NOT use the escutcheon, sprinkler deflector, or fusible element to start or thread the sprinkler into a fitting.

Step 5: Test the system as required and repair all leaks. If a thread leak occurs, normally the unit must be removed, new pipe-joint compound or Teflon® tape applied, and then reinstalled. This is due to the fact that when the joint seal leaks, the sealing compound or tape is washed out of the joint.

Step 6: **Remove plastic protective sprinkler caps and bulb shields AFTER the wall or ceiling finish work is completed where the sprinkler is installed and there no longer is a potential for mechanical damage to the sprinkler operating elements.** To remove the bulb shields, simply pull the ends of the shields apart where they are snapped together. To remove caps from frame style sprinklers, turn the caps slightly and pull them off the sprinklers. **SPRINKLER CAPS AND BULB SHIELDS MUST BE REMOVED FROM SPRINKLERS BEFORE PLACING THE SYSTEM IN SERVICE!** Retain a protective cap in the spare sprinkler cabinet.

Step 7: After installing the ceiling or wall with the required opening size, press on or thread on (depends on the style of escutcheon used) the outer escutcheon cup until the flanges touch the surface of the ceiling or wall.



TECHNICAL DATA

SPRINKLER ESCUTCHEONS

The Viking Corporation, 210 N Industrial Park Road, Hastings MI 49058

Telephone: 269-945-9501 Technical Services 877-384-5464 Fax: 269-945-4495 Email: techsvcs@vikingcorp.com

(NOTE: If the optional escutcheon expansion plate is used, first slide it onto the escutcheon cup. The flange on the expansion plate should touch the surface of the ceiling or wall.)

With the slip-on style Micromatic® Model E-1 Recessed Escutcheon, the maximum adapter recess is 5/8" (16 mm).

With the threaded style Micromatic® Model E-2 Recessed Escutcheon, the maximum recess is 1/2" (12.7 mm). Note: The face of the escutcheon adapter may extend up to 11/32" (8.7 mm) beyond edge of escutcheon cup, resulting in 27/32" (21.4 mm) total adjustment range.

With the Microfast® Model F-1 Adjustable Escutcheon, the maximum recess is 1/4" (6.4 mm). Note: The face of the escutcheon adapter may extend up to 1/4" (6.4 mm) beyond the edge of the escutcheon cup, resulting in 1/2" (12.7 mm) total adjustment range.

With the slip-on style Model G-1 Recessed Escutcheon, the maximum adapter recess is 1/2" (12.7 mm).

DO NOT modify the unit. If necessary, re-cut the sprinkler drop nipple as required.

E. Standard Flat and Raised Surface-Mounted Escutcheons:

Step 1: Install all piping and cut the sprinkler nipple so that the reducing coupling is at the desired location and centered in a maximum 2-1/2" (64 mm) diameter opening in the ceiling or wall.

Step 2: Secure the escutcheon onto the sprinkler by hand turning the escutcheon clockwise onto the sprinkler threads. (The convex surface of the escutcheon must face toward the deflector of the sprinkler.)

Step 3: Apply a small amount of pipe-joint compound or Teflon® tape to the external threads of the sprinkler only, taking care not to allow a build-up of compound in the sprinkler inlet. NOTE: Sprinklers with protective caps or bulb shields must be contained within the caps or shields before applying pipe-joint compound or tape.

Step 4: Install the sprinkler into the coupling using the special sprinkler wrench only, taking care not to over-tighten or damage the sprinkler operating parts. DO NOT use the escutcheon, sprinkler deflector, or fusible element to start or thread the sprinkler into a fitting.

Step 5: After installation, the entire sprinkler system must be tested. The test must be conducted to comply with the installation standards. Make sure the sprinkler is properly tightened. If a thread leak occurs, normally the unit must be removed, new pipe-joint compound or tape applied, and then reinstalled. This is due to the fact that when the joint seal leaks, the sealing compound or tape is washed out of the joint.

Step 6: **Remove plastic protective sprinkler caps and bulb shields AFTER the wall or ceiling finish work is completed where the sprinkler is installed and there no longer is a potential for mechanical damage to the sprinkler operating elements.** To remove the bulb shields, simply pull the ends of the shields apart where they are snapped together. To remove caps from frame style sprinklers, turn the caps slightly and pull them off the sprinklers. **SPRINKLER CAPS AND BULB SHIELDS MUST BE REMOVED FROM SPRINKLERS BEFORE PLACING THE SYSTEM IN SERVICE!** Retain a protective cap in the spare sprinkler cabinet.

DO NOT modify the unit. If necessary, re-cut the sprinkler drop nipple as required.

F. Disassembly:

The outer cups of Viking adjustable and recessed escutcheons can be removed and reinstalled without removing the sprinklers to allow access above the ceiling or to replace it, if necessary.

1. For slip-on style Micromatic® Model E-1 or G-1 Recessed Escutcheons and Microfast® Model F-1 Adjustable Escutcheons, remove the outer cup simply by pulling it outward and away from the wall or ceiling.
2. To remove the outer cup of the threaded style Micromatic® Model E-2 Recessed Escutcheon, turn it counterclockwise to unthread it from the adapter.

If it is necessary to remove the entire unit, the system must be removed from service. Refer to maintenance instructions on the appropriate sprinkler technical data page and follow all warnings and instructions.

5. OPERATION

Refer to the sprinkler technical data page for the sprinkler model used.

6. INSPECTIONS, TESTS AND MAINTENANCE

Refer to NFPA 25 for Inspection, Testing and Maintenance requirements.

7. AVAILABILITY

Viking sprinklers and escutcheons are available through a network of domestic and international distributors. See The Viking Corporation web site for the closest distributor or contact The Viking Corporation.

8. GUARANTEE

For details of warranty, refer to Viking's current list price schedule or contact Viking directly.



TECHNICAL DATA

SPRINKLER ESCUTCHEONS

The Viking Corporation, 210 N Industrial Park Road, Hastings MI 49058

Telephone: 269-945-9501 Technical Services 877-384-5464 Fax: 269-945-4495 Email: techsvcs@vikingcorp.com

Base Part Number	Material	Style	Sprinkler Thread Size	Available Finishes	Outside Diameter
Standard Flat and Raised Surface-Mounted Escutcheons					
01960A	Steel	Flat	1/2" (15 mm)	B, F	3-5/16" (84.1 mm)
09488	Stainless Steel††	Flat	1/2" (15 mm)	F	3-5/16" (84.1 mm)
01015A	Steel	Flat	3/4" (20 mm)	F	3-5/16" (84.1 mm)
02960A	Steel	Flat	1/2" (15 mm)	B, F, M/W, M/B	2-3/4" (69.9 mm)
07526	Stainless Steel††	Flat	1/2" (15 mm)	F, M/W	2-3/4" (69.9 mm)
05464A	Steel	Flat	3/4" (20 mm)	B, F, M/W	2-3/4" (69.9 mm)
09596	Stainless Steel††	Flat	3/4" (20 mm)	F	2-3/4" (69.9 mm)
01961B	Brass	Raised	1/2" (15 mm)	B, F	3-1/16" (77.7 mm)
01016A	Brass	Raised	3/4" (20 mm)	F	3-1/16" (77.7 mm)
E-1 Slip-on Style Recessed Escutcheon Packages (includes adapter and outer cup)					
11123	Steel	Recessed Slip-on	3/8" (10 mm)	F, M/W	3-1/16" (77.7 mm)
06419A	Steel	Recessed Slip-on	1/2" (15 mm)	B, F, M/W, M/B, B/A, B/B, F/B, E/B	3-1/16" (77.7 mm)
07902	Stainless Steel	Recessed Slip-on	1/2" (15 mm)	F, M/W	3-1/16" (77.7 mm)
13220	Stainless Steel	Recessed Slip-on	3/4" (20 mm)	F, M/W	3-1/16" (77.7 mm)
06420A	Steel	Recessed Slip-on	3/4" (20 mm)	B, F, M/W, M/B	3-1/16" (77.7 mm)
E-2 Threaded Style Recessed Escutcheon Packages (includes adapter and outer cup)					
11038	Steel	Recessed Threaded	1/2" (15 mm)	F, M/W	3-1/8" (79.4 mm)
11625	Steel	Recessed Threaded	3/4" (20 mm)	F, M/W	3-1/8" (79.4 mm)
F-1 Adjustable Escutcheon Packages (includes adapter and outer cup)					
06911A	Steel	Adjustable	1/2" (15 mm)	B, F, M/W, M/B	3-1/16" (77.7 mm)
06912A	Steel	Adjustable	3/4" (20 mm)	B, F, M/W, M/B	3-1/16" (77.7 mm)
G-1 Recessed Escutcheon Package (includes adapter and outer cup)					
14315	Steel	Recessed Slip-on	1/2" (15 mm)	B, F, M/W, M/B	4" (101.6 mm)
Escutcheon Cups Available Separately for Adjustable and Recessed Escutcheons					
05459A	Steel	E-1 Recessed & F-1 Adjustable	3/8", 1/2", & 3/4" (10, 15, & 20 mm)	B, F, M/W, M/B	--
07529	Stainless Steel	E-1 Recessed & F-1 Adjustable	1/2" & 3/4" (15 & 20 mm)	F, M/W	--
10920	Steel	E-2 Recessed Threaded	1/2" & 3/4" (15 & 20 mm)	F, M/W	--
14316	Steel	G-1 Recessed	1/2" (15 mm)	B, F, M/W, M/B	--
Optional Expansion Plates Available Separately					
12620	Steel	E-1, E-2 Recessed & F-1 Adjustable	3/8", 1/2", & 3/4" (10, 15, & 20 mm)	B, F, M/W	5" (127 mm)
13128	Steel	Domed Concealed	1/2" & 3/4" (15 & 20 mm)	B, F, M/W	5" (127 mm)
Escutcheon Adapters Available Separately for Adjustable and Recessed Escutcheons					
11049	Steel	E-1 Recessed	3/8" (10 mm)	F, M/W	--
06408B	Steel	E-1 Recessed	1/2" (15 mm)	B, F, M/W, M/B	--
06599B	Steel	F-1 Recessed	1/2" (15 mm)	B, F, M/W, M/B	--
07527	Stainless Steel	E-1 Recessed	1/2" (15 mm)	F, M/W	--
13219	Stainless Steel	E-1 Recessed	3/4" (20 mm)	F, M/W	--
06409B	Steel	E-1 Recessed	3/4" (20 mm)	B, F, M/W, M/B	--
06600B	Steel	F-1 Recessed	3/4" (20 mm)	B, F, M/W, M/B	--
10921	Steel	E-2 Recessed	1/2" (15 mm)	F, M/W	--
11623	Steel	E-2 Recessed	3/4" (20 mm)	F, M/W	--
14317	Steel	G-1 Recessed	1/2" (15 mm)	B, F, M/W, M/B	--

Escutcheon Finishes: B = Bright Brass, F = Polished Chrome, M/W = White Polyester, M/B = Black Polyester, B/A = Antique Brass, B/B = Brushed Brass, F/B = Brushed Chrome, E/B = Brushed Copper. Note: Other colors are available on request with the same listings and approvals as the standard colors. See Sherwin-Williams® Color Answers™ Interior Color Selection color chart.

††Escutcheons 09488, 07526, and 09596 may also be special ordered and manufactured from Brass (non-magnetic material). Contact the manufacturer for more details.

Table 1

	TECHNICAL DATA	SPRINKLER ESCUTCHEONS
---	-----------------------	------------------------------

The Viking Corporation, 210 N Industrial Park Road, Hastings MI 49058
 Telephone: 269-945-9501 Technical Services 877-384-5464 Fax: 269-945-4495 Email: techsvcs@vikingcorp.com

IMPORTANT NOTES

Per the current edition of NFPA 13: "Escutcheons used with recessed, flush-type, or concealed sprinklers shall be part of a listed sprinkler assembly." The Viking Corporation will not authorize the sale of unlisted recessed sprinkler assemblies nor assume any liability involving recessed sprinkler assemblies that are not considered cULus Listed, FM Approved, or in full compliance with NFPA requirements".

Listings and approvals vary, depending on the sprinkler model, temperature rating, finish, and occupancy classification.

WARNING: Viking products are manufactured and tested to meet the rigid requirements of the approving agency. The sprinklers are designed to be installed in accordance with recognized installation standards. Deviation from the standards or any alteration to the sprinkler after it leaves the factory including, but not limited to: painting, plating, coating, or modification, may render the sprinkler inoperative and will nullify the approval and any guarantee made by The Viking Corporation.

IMPORTANT: Always refer to Bulletin Form No. F_091699 - Care and Handling of Sprinklers. Also refer to the appropriate sprinkler data page. Viking sprinklers are designed to be installed in accordance with the latest edition of Viking technical data, the latest standards of NFPA, FM Global, LPCB, APSAD, VdS or other similar organizations, and also with the provisions of governmental codes, ordinances, and standards whenever applicable. The use of certain types of sprinklers may be limited due to occupancy and hazard. Refer to the Authority Having Jurisdiction prior to installation.

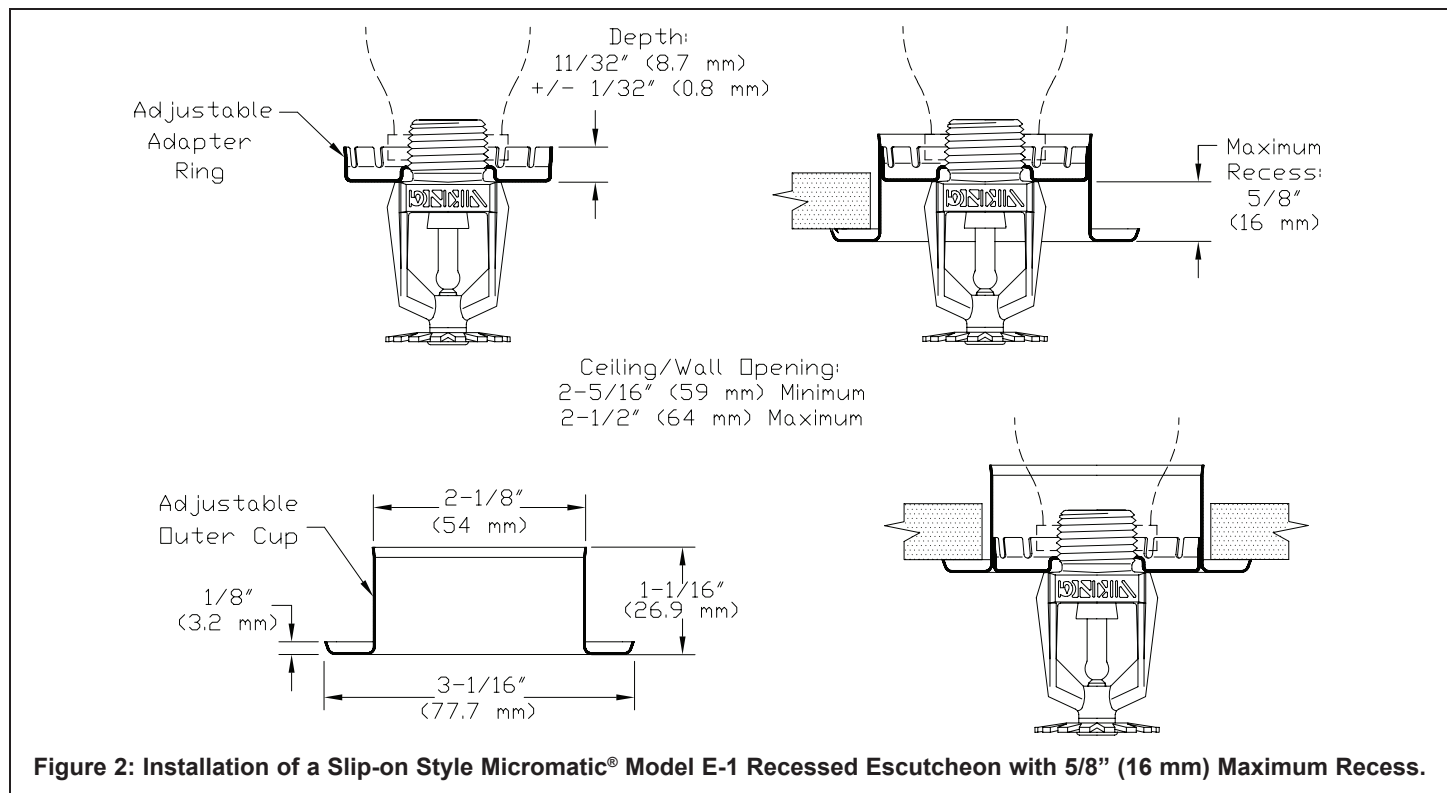



TECHNICAL DATA

SPRINKLER ESCUTCHEONS

The Viking Corporation, 210 N Industrial Park Road, Hastings MI 49058

Telephone: 269-945-9501 Technical Services 877-384-5464 Fax: 269-945-4495 Email: techsvcs@vikingcorp.com

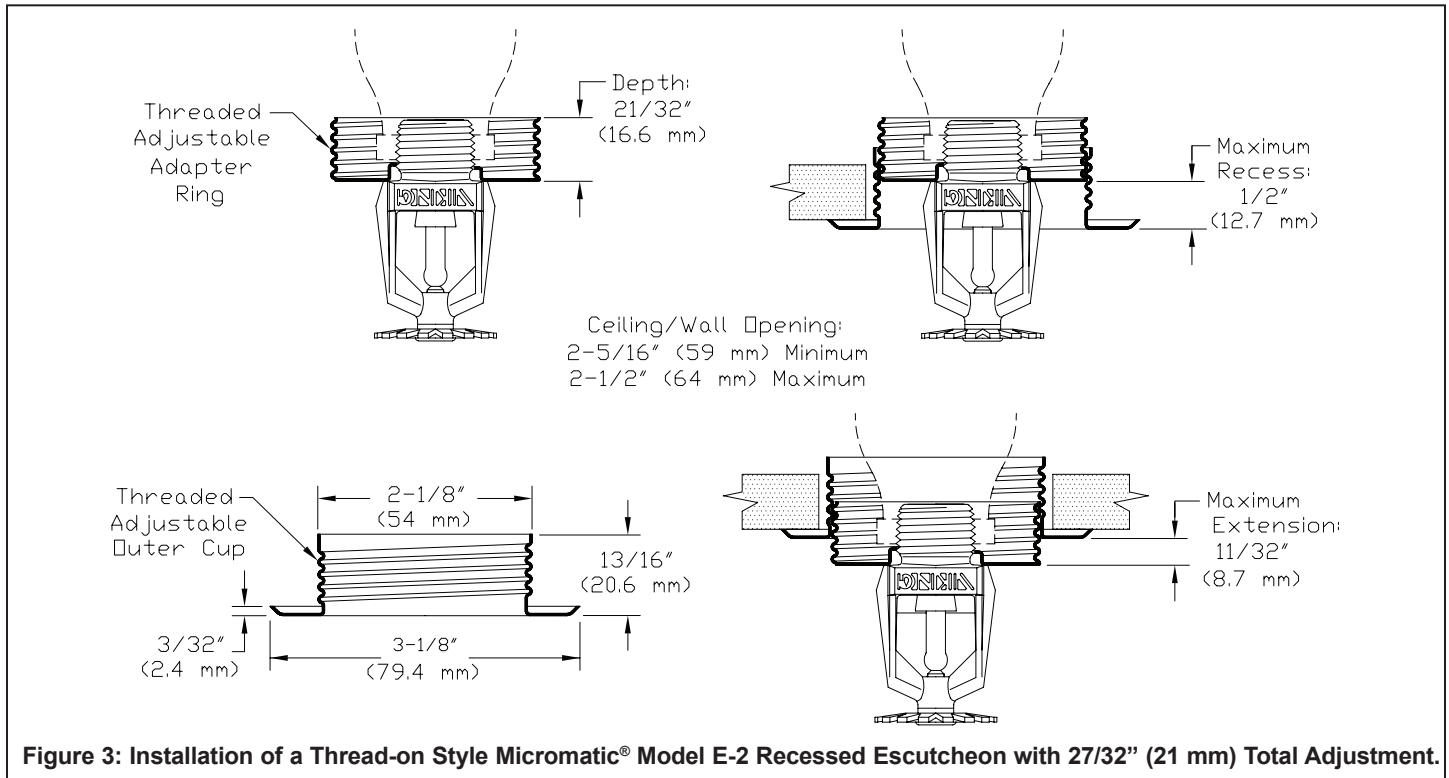

Figure 3: Installation of a Thread-on Style Micromatic® Model E-2 Recessed Escutcheon with 27/32" (21 mm) Total Adjustment.

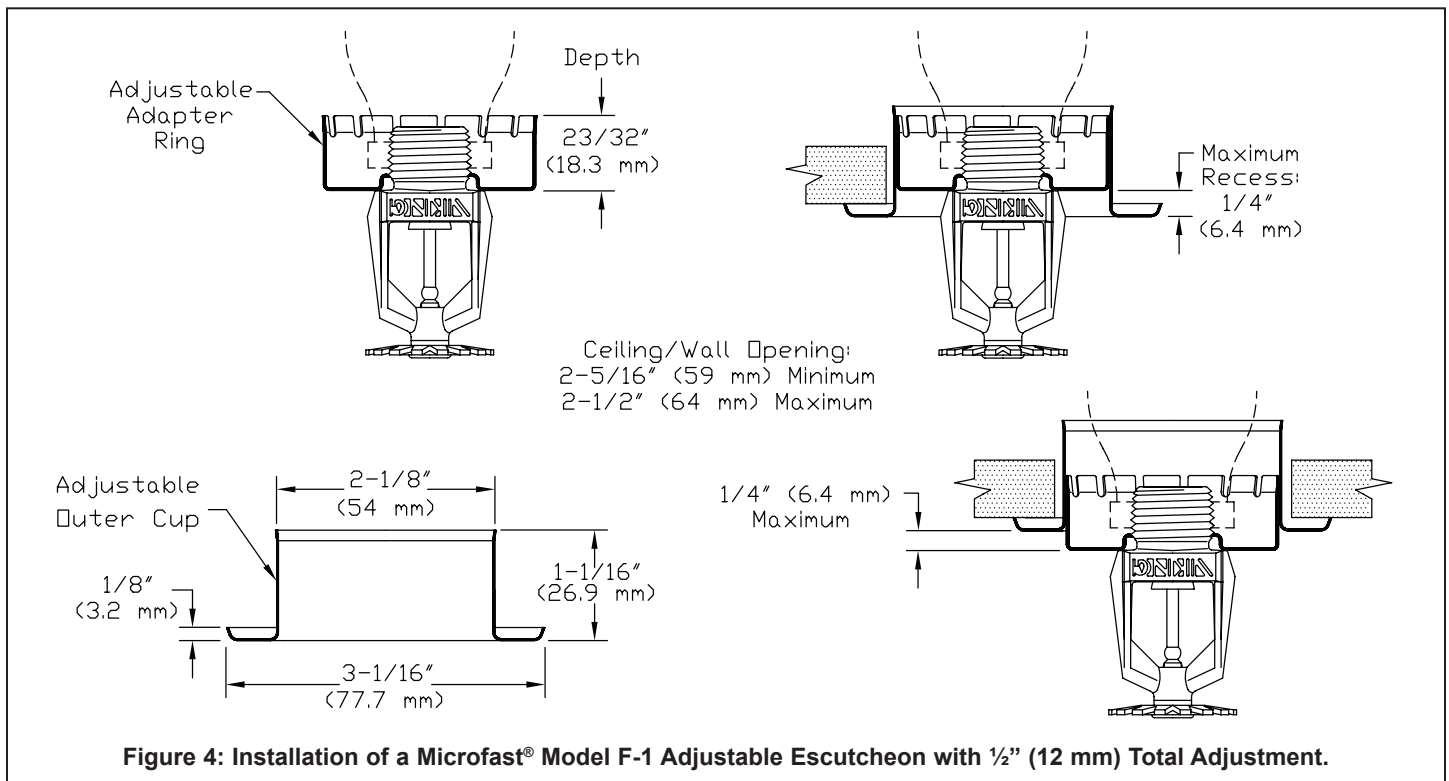

Figure 4: Installation of a Microfast® Model F-1 Adjustable Escutcheon with 1/2" (12 mm) Total Adjustment.



TECHNICAL DATA

SPRINKLER ESCUTCHEONS

The Viking Corporation, 210 N Industrial Park Road, Hastings MI 49058

Telephone: 269-945-9501 Technical Services 877-384-5464 Fax: 269-945-4495 Email: techsvcs@vikingcorp.com

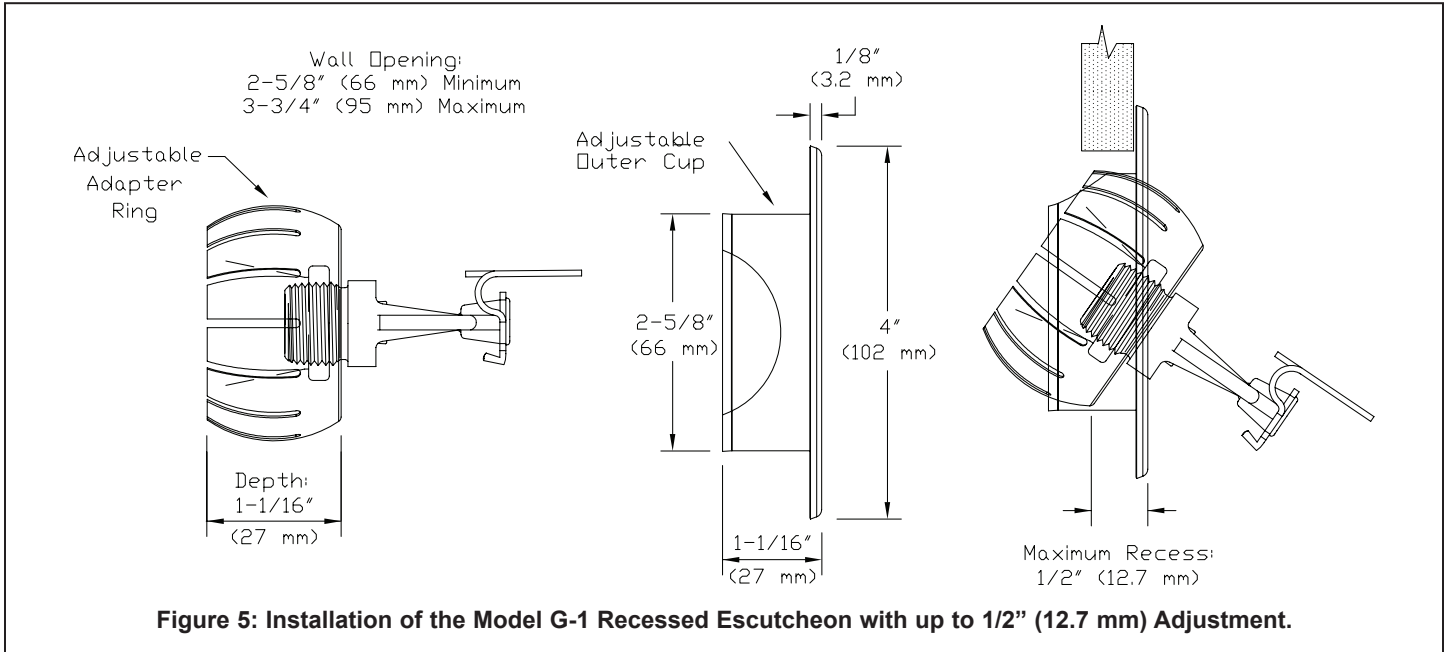

Figure 5: Installation of the Model G-1 Recessed Escutcheon with up to 1/2" (12.7 mm) Adjustment.

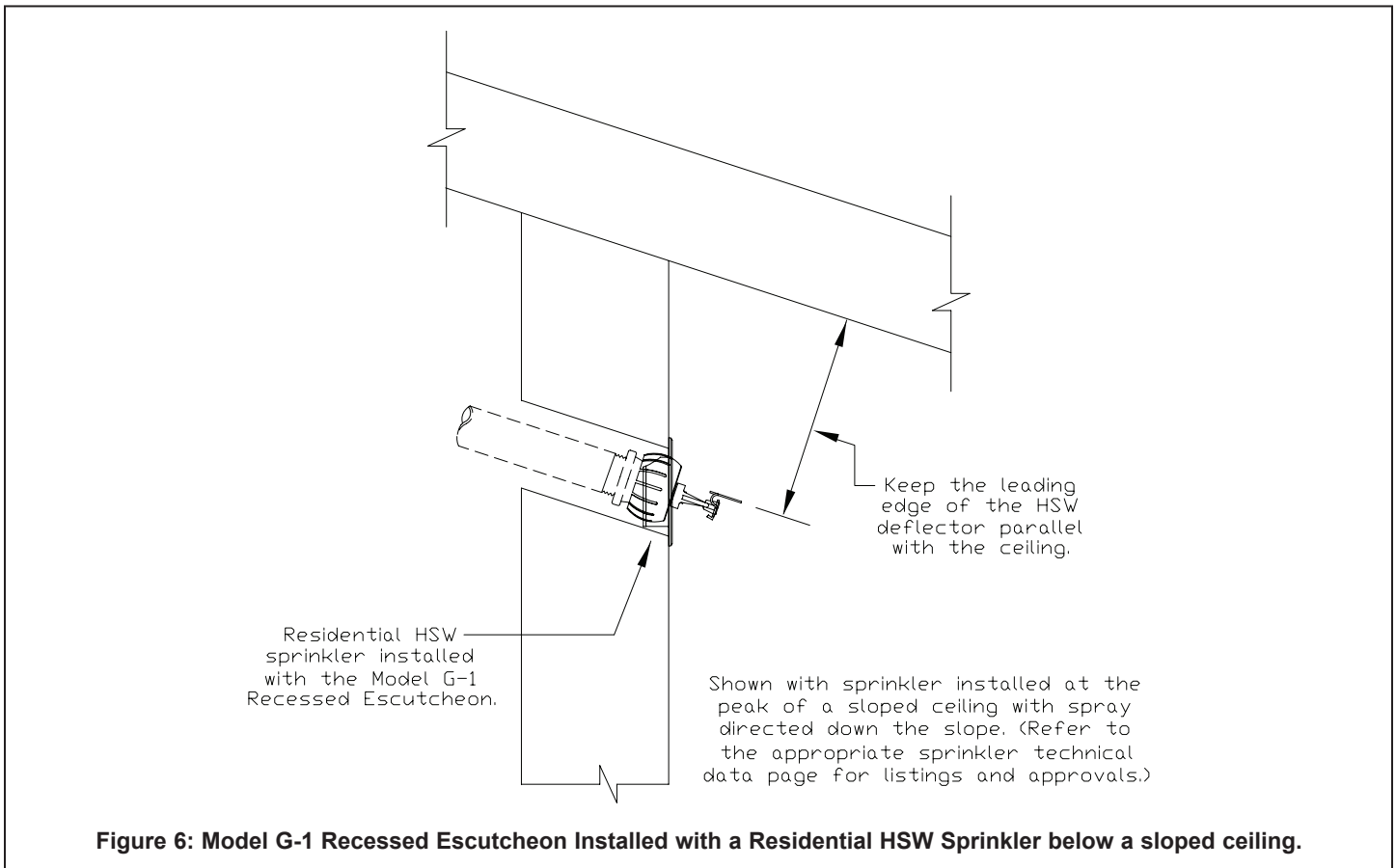

Figure 6: Model G-1 Recessed Escutcheon Installed with a Residential HSW Sprinkler below a sloped ceiling.