

ALARM VALVE

3" MODEL "B"

Flange/Flange



Listed by: Underwriters Laboratories Inc.
Approved by: Factory Mutual

"ASTRA" 3"ALARM VALVE MODEL "B"

Flange/Flange

DESCRIPTION AND OPERATION

The Astra Model "B" Alarm Valve, differential type, consists of a rubber faced bronze swing clapper seating on a grooved bronze seat. The seat is tinned to prevent the rubber clapper facing from sticking to the seat. An external by-pass allows a pressure surge from the supply side to by-pass the alarm valve clapper and become entrapped in the sprinkler system thus creating an excess system pressure that will steady the clapper.

When a sprinkler head or inspector test valve is opened, pressure on the system side of the clapper is reduced below the pressure of the supply side. When this happens, the drop of pressure in the system side is greater than the designed capacity of the Excess Pressure Pump. The valve now trips, raising the clapper off the grooved seat permitting water to flow to the system and to the alarm devices through the alarm lines. These are usually a circuit closer or opener, that rings an electrical alarm, and a water motor gong, which rings a mechanical alarm.

The E.P.P. has a strainer in the intake line to prevent foreign matters from clogging the pump. The E.P.P. by taking water from below the Alarm Valve clapper and pumping it in the system side builds up a pressure of approximately 40 P.S.I. (276 k Pa) above the main pressure, thereby keeping the Alarm Valve in a close position and preventing a false alarm in case of water surge.

Parts list

ITEM	Part No.	DWG. No.	DESCRIPTION
1	AV-310-1	AVB 3005	Body
2	AV-310-7	AV 3011	Water seat
3	AV-310-2	AV 3021	Cover
4	AV-310-17	AV 3019	Cover gasket
5	AV-310-3	AV 3008	Cover Bolts
6	AV-310-19	AV 3010	Clapper
7	AV-310-9	AV 3013	Clapper Pin
8	AV-310-8	AV 3012	Bushing
9	AV-310-10	AV 3014	Plug
10	AV-310-16	AV 3018	Clapper gasket
11	AV-310-14	AV 3016	Seal retainer
12	AV-310-11	AV 3015	Bolt
13	AV-310-15	AV 3026	"O" Ring
14	AV-310-13	AV 3015	Lockwasher
15	AV-310-12	AV 3015	Nut

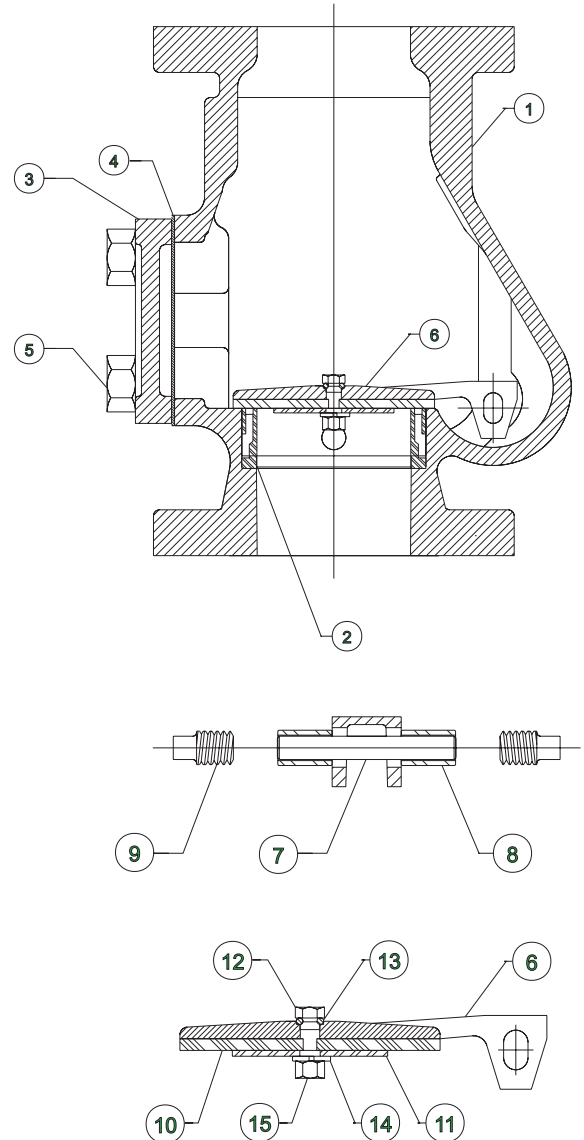

3" Alarm Valve Model B	
Face to face	10 3/4"
Weight	52 lbs.

3" ALARM TRIM (ASTRA) (TO USE WITH EXCESS PRESSURE PUMP)

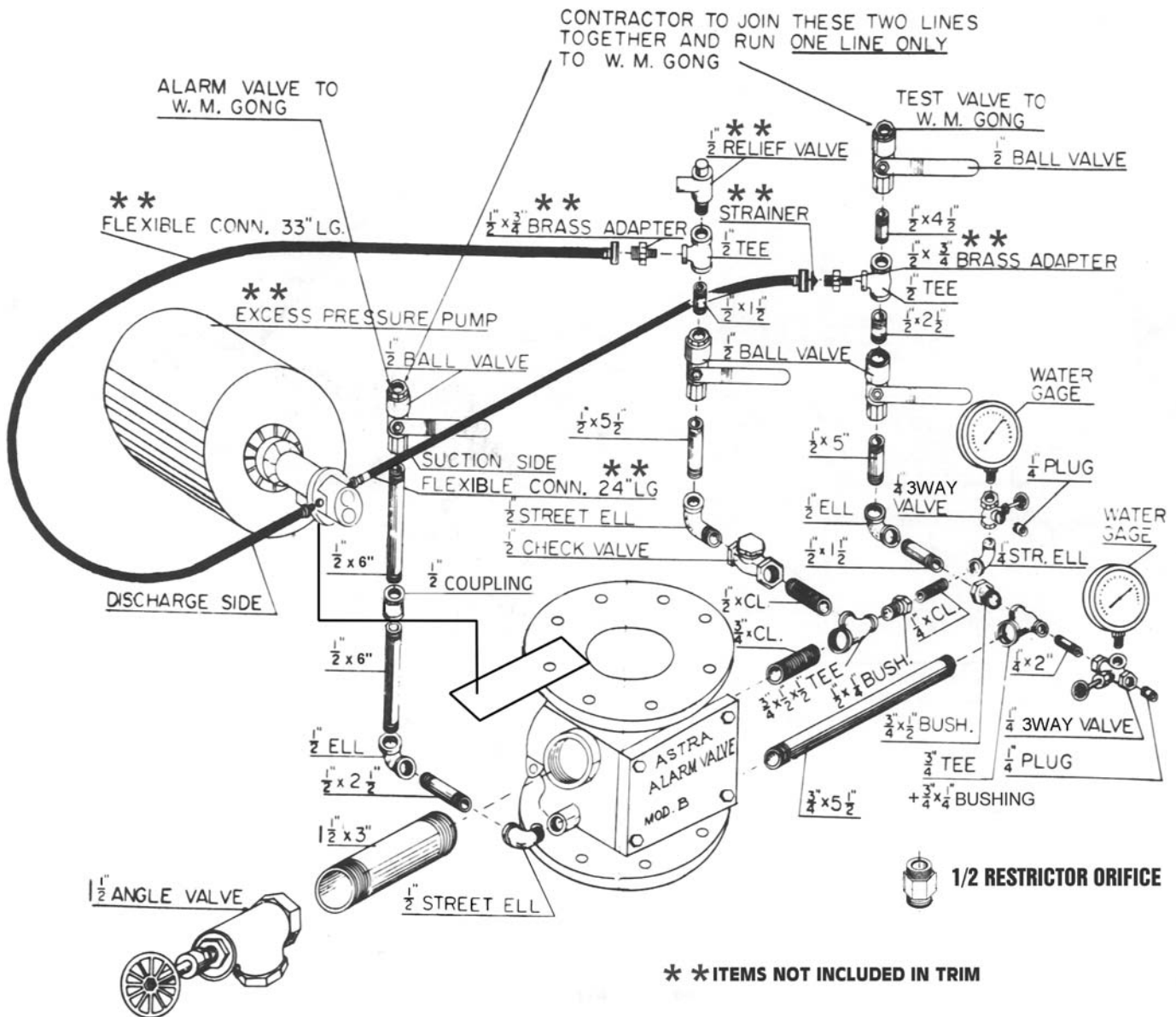

3" ALARM TRIM (ASTRA) (TO USE WITH RETARD CHAMBER)

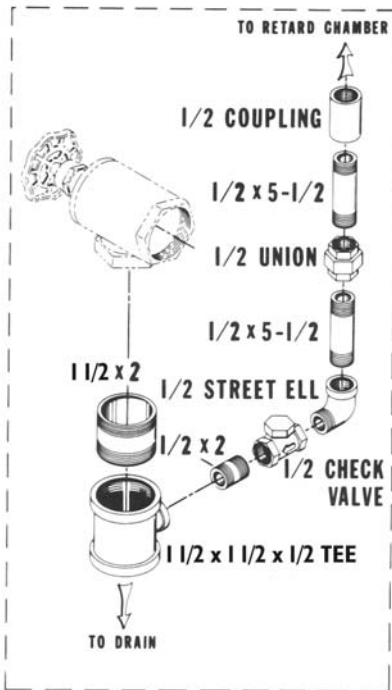

OPTIONAL - NOT INCLUDED
IN STANDARD TRIM

