

ALARM VALVE

6" MODEL "D"

Flange/Groove



Listed by: Underwriters Laboratories Inc.
Underwriters Laboratories of Canada
Approved by: Factory Mutual

“ASTRA” 6” ALARM VALVE MODEL “D”

Flange/Groove

DESCRIPTION AND OPERATION

The “Astra” 6” Alarm Valve model “D” must be installed vertically in the main supply to a wet type sprinkler system. Where water pressure fluctuates, such as encountered with city water supplies, variable pressure trim including an Excess Pressure Pump must be used. For installations where water pressure does not fluctuate, such as tank supplies, constant pressure trim is used without the need of an Excess Pressure Pump.

Care must be exercised when installing check valves in the trim to be certain that they are located with the arrow on the body pointing in the proper direction. The arrow on the body of the 1/2” check valve **must** point toward the alarm valve body.

Parts list

ITEM	Part No.	DWG No	DESCRIPTION
1	AV-16-1	AVD 6007	Body
2	AV-16-7	AV 6013	Water seat
3	AV-16-2	AV 6023	Cover
4	AV-16-17	AV 6021	Cover gasket
5	AV-16-3	AV 6010	Cover bolt
6	AV-16-19	AV 6012	Clapper
7	AV-16-9	AV 6015	Clapper pin
8	AV-16-8	AV 6014	Bushing
9	AV-16-10	AV 6016	Plug
10	AV-16-16	AV 6020	Clapper gasket
11	AV-16-14	AV 6018	Seal retainer
12	AV-16-11	AV 6017	Bolt
13	AV-16-15	AV 6019	O' Ring
14	AV-16-13	AV 6017	Lockwasher
15	AV-16-12	AV 6017	Nut

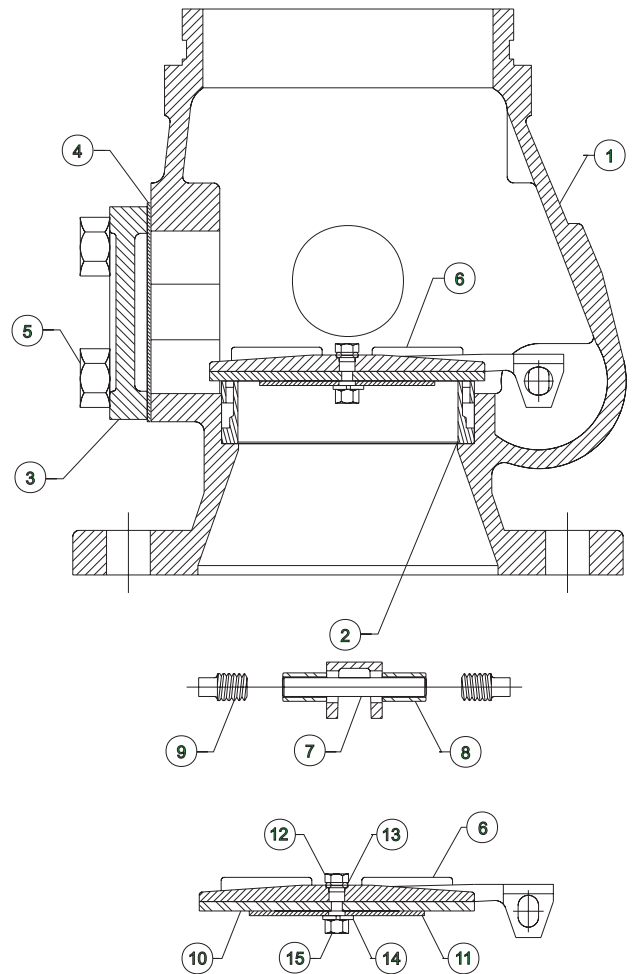

6" Alarm Valve Model “D”	
Face to face	11 5/16"
Weight	65 lbs.

