



TECHNICAL DATA

FLOW CONTROL VALVE MODEL H-1 3" (DN80), 4" (DN100) & 6" (DN150)

The Viking Corporation, 210 N Industrial Park Road, Hastings MI 49058

Telephone: 269-945-9501 Technical Services: 877-384-5464 Fax: 269-945-4495 Email: techsvcs@vikingcorp.com

1. DESCRIPTION

The Viking Flow Control Valve is a quick opening, differential type flood valve with a spring loaded rolling diaphragm clapper. The Flow Control Valve can be used to facilitate manual or automatic on/off control. As an on/off control valve it may be used on Deluge Systems, Sprinkler Systems or to automatically fill tanks or reservoirs. The Viking Flow Control valve is an integral part of the Viking Firecycle® System.

FEATURES

- A. Field replaceable Diaphragms and Rubber Seated Clapper Assembly
- B. Designed to be reset without opening the valve
- C. Compatible with Hydraulic, Pneumatic and/or Electric Release Systems



2. LISTINGS AND APPROVALS:

For 250 PSI (17.2 bar) WWP
U.L. Listed - VLFT and VLLA
C-UL Listed
FM Approved - On-Off Multicycle Sprinkler Systems
ABS Approved - 04-CH557068-X
For 175 PSI (12.1 bar) WWP
NYC Board of Standards and Appeals: Calendar Number 219-76-SA

3. TECHNICAL DATA

Specifications:

Style: 90 Degree Pattern (inlet to outlet)
Connections: See Table 1
Rated to: 250 psi (17.2 bar) water working pressure
Factory tested to: 500 psi (34.5 bar)
Priming chamber supply restriction (required): 1/8" (3.2 mm)
Color: Red
Cv Factor: See Table 1

Table 1: Valve Part Numbers and Specifications

Description	Nominal Size	Part Number	Friction Loss*	Cv Factor	Shipping Weight
Flange/Flange					
Flange Drilling					
ANSI	3"	05914C	22 ft. (6.7m)	200	73 lbs. (33 kg)
ANSI	4"	05911C	16 ft. (4.9m)	471	123 lbs. (56 kg)
ANSI	6"	05908C	31 ft. (9.4m)	987	251 lbs. (114 kg)
ANSI/Japan	4"	09037	16 ft. (4.9m)	471	123 lbs. (56 kg)
ANSI/Japan	6"	09386	31 ft. (9.4m)	987	251 lbs. (114 kg)
PN10/16	DN80	08627	22 ft. (6.7m)	48**	73 lbs. (33 kg)
PN10/16	DN100	08630	16 ft. (4.9m)	113.2**	123 lbs. (56 kg)
PN10/16	DN150	08632	31 ft. (9.4m)	237.2**	251 lbs. (114 kg)
Flange/Groove					
Flange Drilling / Pipe O.D.					
ANSI / 89mm	3"	05837C	22 ft. (6.7m)	200	66 lbs. (30 kg)
ANSI / 114mm	4"	05841C	16 ft. (4.9m)	471	112 lbs. (51 kg)
ANSI / 168mm	6"	05458C	31 ft. (9.4m)	987	236 lbs. (107 kg)
PN10/16 / 89mm	DN80	11658	22 ft. (6.7m)	48**	66 lbs. (30 kg)
PN10/16 / 114mm	DN100	11811	16 ft. (4.9m)	113.2**	112 lbs. (51 kg)
PN10/16 / 168mm	DN150	05458C	31 ft. (9.4m)	987	236 lbs. (107 kg)

* Expressed in equivalent length of Schedule 40 pipe based on Hazen & Williams formula. C=120
** Expressed in Metric Units

Systems with water working pressures above 175 PSI (1 207 kPa) may require extra-heavy pattern fittings. Viking Model H-1 Flow Control Valve flanges are Ductile Iron ANSI B16.42 Class 150 with a maximum water working pressure of 250 PSI. ANSI B16.42 Class 150 flanges are NOT compatible with ANSI Class 250 or Class 300 flanges. To mate the Model H-1 Flow Control Valve with ANSI Class 250 or Class 300 flanges, use the grooved-outlet style valve, installed with listed groove/flange adapters of the appropriate pressure rating. For piping with grooved connections, the grooved-outlet style valve may be installed with listed grooved couplings of the appropriate pressure rating.

	<h1>TECHNICAL DATA</h1>	<h2>FLOW CONTROL VALVE MODEL H-1</h2> <p>3" (DN80), 4" (DN100) & 6" (DN150)</p>
---	-------------------------	---

The Viking Corporation, 210 N Industrial Park Road, Hastings MI 49058

Telephone: 269-945-9501 Technical Services: 877-384-5464 Fax: 269-945-4495 Email: techsvcs@vikingcorp.com

Friction loss: See Table 1

Material Standards:

Refer to Materials Chart, Figure 5

Ordering Information:

See Table 1 for part numbers and shipping weights

Accessories:

1. Model H Flow Control Conventional Trim package for use with the Flow Control Valve. The trim package includes all necessary fittings, nipples and devices shown on the Model H Flow Control Valve Conventional Trim Charts. Trim Charts are provided in trim packages and the Viking Engineering and Design Data Book. For optional pre-assembled "modular" trim packages, refer to the Viking list price schedule or contact the manufacturer.
2. Firecycle Trim package for use when the Flow Control Valve is used on a Firecycle system. The trim package includes all necessary fittings, nipples and devices shown on the Viking Firecycle Trim Charts.
3. Auxiliary Components are required for specific valve functions. For complete operating trim requirements refer to system data for the system used.

NOTE: FOR PART NUMBERS OF ACCESSORIES, REFER TO VIKING'S LIST PRICE SCHEDULE.

Viking Technical Data may be found on The Viking Corporation's Web site at <http://www.vikinggroupinc.com>. The Web site may include a more recent edition of this Technical Data Page.

4. INSTALLATION

When Valve Trim is used, to maintain listings and approvals, trim must be installed according to Viking Model H Flow Control Valve Conventional Trim Charts specifically labeled "Maximum 250 PSI Water Working Pressure." Refer to page 512 a-c. Order 250 PSI (17.2 bar) trim separately.

A. General Instruction

1. Viking Flow Control Valves may be installed in any position.

NOTE: FOR POSITIONS OTHER THAN VERTICAL (SHOWN IN FIG. 1) MINOR MODIFICATION OF TRIM MAY BE REQUIRED TO FACILITATE DRAINAGE FROM OUTLETCAMBER OF THE FLOW CONTROL VALVE (CONSULT MANUFACTURER).

2. The valve must be installed in an area not subject to freezing temperatures or physical damage.
3. The valve must be trimmed according to current Viking Trim Charts and appropriate instructions for the system used. Trim Charts are printed in the Viking Engineering and Design Data book, and are provided with trim packages.
4. The priming line must be connected upstream of the system water supply main control valve or to a constant source of water at a pressure equal to the system water supply.
5. After the Flow Control Valve is set, operation of the Flow Control Valve requires the release of priming water from the priming chamber. This may be by automatic or manual operation of the release system. Viking Flow Control Valves are compatible with hydraulic, pneumatic, and electric release systems.
 - a: Hydraulic Release Systems: See Figures 3-5 for the maximum allowable elevation of hydraulic release piping above the Flow Control Valve. If the maximum height of hydraulic release piping exceeds the limit shown in Figures 3-5, use a Pneumatic or Electric Release System.
 - b: Pneumatic Release Systems: A Viking Pneumatic Actuator is required between the release system connection provided on Flow Control Trim and pneumatic release system piping.

CAUTION: WHEN RELEASING DEVICES CAPABLE OF AUTOMATICALLY RESETTING ARE USED ON THE PNEUMATIC RELEASE SYSTEM OF A FLOW CONTROL VALVE, VIKING MODEL E DELUGE VALVE CONVENTIONAL TRIM, COMPLETE WITH PORV, IS REQUIRED.

NOTE: THIS ARRANGEMENT WILL NOT ALLOW THE FLOW CONTROL VALVE TO AUTOMATICALLY RESET.

c: Electric Release: Solenoid Valves, Release Control Panels, and Electrical Detectors must be compatible. Consult appropriate listings and/or approval guides.

6. The Viking Flow Control Valve can be trimmed to automatically reset electrically or manually. For specific Trim arrangements refer to System Data describing the system being installed.

NOTE: DO NOT INSTALL ANY RELEASING DEVICE, OR VALVE USED TO AUTOMATICALLY RESET THE FLOW CONTROL VALVE, ON PNEUMATIC RELEASE PIPING.

For pneumatic release systems, any releasing valve or device used to automatically reset the Flow Control Valve must be installed in the trim piping between the Pneumatic Actuator and the priming chamber outlet.

CAUTION: OPERATION OF VIKING FLOW CONTROL VALVES BY PRESSURIZING THE PRIMING CHAMBER WITH AIR OR ANY OTHER PRESSURIZED GAS IS NOT RECOMMENDED OR APPROVED.

B. Placing the Valve in Service (Refer to Figure 1)

1. Verify:

VIKING®

TECHNICAL DATA

**FLOW CONTROL VALVE
MODEL H-1
3" (DN80), 4" (DN100) & 6" (DN150)**

The Viking Corporation, 210 N Industrial Park Road, Hastings MI 49058

Telephone: 269-945-9501 Technical Services: 877-384-5464 Fax: 269-945-4495 Email: techsvcs@vikingcorp.com

- a. The system Main Water Supply Control Valve (D.1) is closed and the Flow Control Valve is trimmed according to current Viking Trim Charts and schematic drawings for the system used.
 - b. The system has been properly drained.
 - c. The Auxiliary Drain (B.6) is open.
 - d. The Emergency Release (B.11) is closed.
 - e. The system water supply piping is pressurized up to the closed Main Water Supply Control Valve (D.1) and the priming line is pressurized up to closed Priming Valve (B.1).
2. For Systems equipped with:
 - a. Hydraulic Release System
 - i. Verify that all releasing devices are set and that any Inspector's Test Valve and/or auxiliary drain valves are closed.
 - ii. Open Priming Valve (B.1) Proceed to step 3.
 - b. Pneumatic Release Systems:
 - i. Set the release system
 - ii. Opening Priming Valve (B.1). Proceed to step 3.
 - c. Electric Release Systems:
 - i. Open Priming Valve (B.1)
 - ii. Set the electric release system. Proceed to step 3.
 3. Open Flow Test Valve (B.15)
 4. Partially open Main Water Supply Control Valve (D.1).
 5. When full flow develops from Flow Test Valve (B.15), close the Flow Test Valve. Verify that there is no flow from open Auxiliary Drain (B.6).
 6. Close Auxiliary Drain (B.6).
 7. Fully open and secure the Main Water Supply Control Valve (D.1).
 8. Verify that the Alarm Shut-off Valve (B.9) is open and that all other valves are in their normal operating position.
 9. Depress the plunger of Drip Check (B.7). No water should flow from the Drip Check (B.7) when the plunger is pushed.
 10. Check for, and repair all leaks.
 11. On new installations, those systems that have been placed out of service or where new equipment has been installed, trip test the system to verify that all equipment functions properly. Refer to MAINTENANCE paragraph 6-B: ANNUAL maintenance instructions.

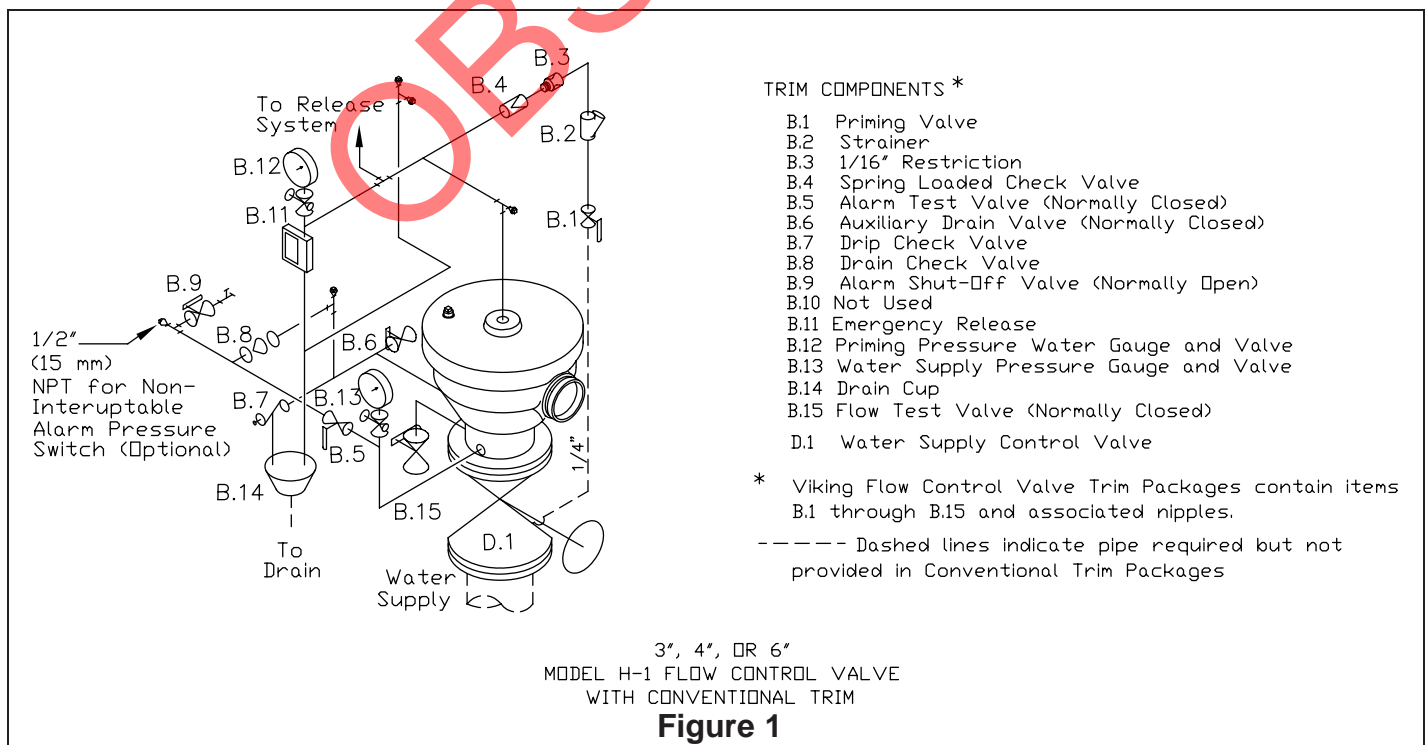



The Viking Corporation, 210 N Industrial Park Road, Hastings MI 49058

Telephone: 269-945-9501 Technical Services: 877-384-5464 Fax: 269-945-4495 Email: techsvcs@vikingcorp.com

CAUTION! PERFORMING A TRIP TEST RESULTS IN OPERATION OF THE FLOW CONTROL VALVE. WATER WILL FLOW INTO THE SPRINKLER PIPING. TAKE NECESSARY PRECAUTIONS TO PREVENT DAMAGE.

12. After completing a trip test, perform SEMI-ANNUAL maintenance.

C. Automatic Resetting (Refer to Figure 1 for identification of trim components)

To automatically reset the Flow Control Valve after it has operated:

1. Do NOT close the water supply main control valve (D.1)
2. Automatically or manually reset any open devices on the hydraulic release system to stop all flow of water out of the priming chamber.

CAUTION: RESETTING OR CLOSING RELEASING DEVICES OR VALVES ON PNEUMATIC RELEASE PIPING WILL NOT AUTOMATICALLY CAUSE THE FLOW CONTROL VALVE TO RESET.

Do NOT install any releasing device or valve used to automatically reset the Flow Control Valve, on pneumatic release piping.

3. System supply pressure will enter the priming chamber through the restricted priming line connected to the priming chamber inlet.
4. When the combined force of spring pressure and system supply pressure entering the priming chamber overcomes the velocity pressure of water flowing through the valve, the clapper will close.
5. Flow through the valve will stop.
6. To reactivate the system, open a releasing device. Priming water will escape from the priming chamber faster than it is replaced through the restricted priming line, allowing the Flow Control Valve to open.

D. Valve Removed from Service

NOTE: WHEN A VALVE HAS BEEN REMOVED FROM SERVICE AND IS SUBJECT TO FREEZING OR WILL BE OUT OF SERVICE FOR AN EXTENDED PERIOD OF TIME, ALL WATER MUST BE REMOVED FROM THE PRIMING CHAMBER, TRIM PIPING, WATER SUPPLY PIPING AND OTHER TRAPPED AREAS.

5. OPERATION (Refer to Figure 5)

NOTE: FOR OPERATION OF A FLOW CONTROL VALVE ON A VIKING FIRECYCLE SYSTEM, REFER TO FIRECYCLE TECHNICAL DATA.

The Viking Flow Control Valve has an inlet chamber, an outlet chamber and a priming chamber. The inlet chamber and outlet chamber are separated from the priming chamber by a diaphragm and clapper assembly. System pressure enters the priming chamber through a restricted priming line (trim) equipped with a check valve.

In the set condition:

System pressure is trapped in the priming chamber to hold clapper (6) on seat (9) due to area differential of the clapper, and spring (11) pressure. The clapper (6) separates the inlet from the outlet, keeping the system piping dry.

In fire conditions:

Pressure is released from the priming chamber faster than it is re-supplied through the restricted priming line. Water supply pressure in the inlet chamber forces the clapper open allowing water to flow through the outlet and into the system and alarm devices.

To automatically reset, flow of water out of the priming chamber is stopped. This can be done manually (by closing a valve in the hydraulic release piping), or electrically (by closing a solenoid valve in the hydraulic release piping). When the combined force of spring (11) pressure and system supply pressure entering the priming chamber overcomes the velocity pressure of water flowing through the valve, the clapper (6) will close. Flow through the valve will stop.

6. INSPECTIONS, TESTS AND MAINTENANCE (Refer to Figure 1)

A. Inspection

It is imperative that the system be inspected and tested on a regular basis. The frequency of the inspections may vary due to contaminated water supplies, corrosive water supplies or corrosive atmospheres. Also, the alarm devices, detection systems or other connected trim may require a more frequent schedule. For minimum maintenance and inspection requirements, refer to NFPA 25. In addition, the Authority Having Jurisdiction may have additional maintenance, testing, and inspection requirements which must be followed. The following recommendations are minimum requirements.

Weekly:

Weekly visual inspection of the Viking Flow Control Valve is recommended.

1. Verify that the Main Water Supply Control Valve (D.1) is open and that all other valves are in their normal operating position and appropriately secured.



The Viking Corporation, 210 N Industrial Park Road, Hastings MI 49058

Telephone: 269-945-9501 Technical Services: 877-384-5464 Fax: 269-945-4495 Email: techsvcs@vikingcorp.com

2. Check for signs of mechanical damage, leakage, and/or corrosive activity. If detected, perform maintenance as required. If necessary, replace the device.
3. Verify that the valve and trim are adequately heated and protected from freezing and physical damage.

B. Tests

Quarterly:

Quarterly testing of water flow alarms and performance of a Main Drain Test is recommended and may be required by the Authority Having Jurisdiction.

I. Water Flow Alarm Test

1. Notify the Authority Having Jurisdiction and those in the area affected by the test.
2. To test the local electric alarm (if provided) and/or mechanical water motor alarm (if provided), OPEN the alarm test valve (B.5) in the Flow Control Valve trim.
 - a. Electric alarm pressure switches (if provided) should activate.
 - b. Electric local alarms should be audible.
 - c. The local water motor gong should be audible.
 - d. If equipped with remote station alarm signaling devices, verify that alarm signals were received.
3. When testing is complete, CLOSE the alarm test valve (B.5).
Verify:
 - a. All local alarms stop sounding and alarm panels (if provided) reset.
 - b. All remote station alarms reset.
 - c. Supply piping to water motor alarm properly drains.
4. Verify that the alarm shut-off valve (B.9) is OPEN, and the alarm test valve (B.5) is CLOSED.
5. Verify that the outlet chamber is free of water. No water should flow from the drip check (B.7) when the plunger is pushed.
6. Notify the Authority Having Jurisdiction and those in the affected area that testing is complete.

II: Main Drain Test

1. Notify the Authority Having Jurisdiction and those in the area affected by the test.
2. Record pressure reading from the water supply pressure gauge (B.13).
3. Verify that the outlet chamber of the Flow Control Valve is free of water. No water should flow from the drip check (B.7) when the plunger is pushed.
4. Fully OPEN the Flow Test Valve (B.15).
5. When a full flow is developed from the Flow Test Valve (B.15), record the residual pressure from the water supply pressure gauge (B.13).
6. When the test is complete, SLOWLY CLOSE the Flow Test Valve (B.15).
7. Compare test results with previous flow information. If deterioration of the water supply is detected, take appropriate steps to restore adequate water supply.
8. Verify:
 - a. Normal water supply pressure has been restored to the inlet chamber, the priming chamber, and the release system. The pressure on the priming chamber water pressure gauge should equal the system water supply pressure.
 - b. All alarm devices, and valves are secured in normal operating position.
9. Notify the Authority Having Jurisdiction that the test is complete. Record and/or provide notification of test results as required by the Authority Having Jurisdiction.

Annual:

Annual Trip Tests are recommended.

CAUTION! PERFORMING THIS TEST RESULTS IN OPERATION OF THE FLOW CONTROL VALVE. WATER WILL FLOW INTO THE SPRINKLER PIPING AND FROM ANY OPEN SPRINKLERS AND/OR NOZZLES. TAKE NECESSARY PRECAUTIONS TO PREVENT DAMAGE.

1. Notify the Authority Having Jurisdiction and those in the area affected by the test.
2. Fully open the Flow Test Valve (B.15) to flush away any accumulation of foreign material.
3. Close the Flow Test Valve (B.15).
4. Trip the system by operating the release system. Allow a full flow to pass through the Flow Control Valve. Water flow alarms should operate.

When test is complete:

5. For Flow Control Valves equipped with:
 - a. Hydraulic or Electric Release:
 - i. Reset the Release System. Pressure in the priming chamber should gradually be restored. Flow through the Flow Control



The Viking Corporation, 210 N Industrial Park Road, Hastings MI 49058

Telephone: 269-945-9501 Technical Services: 877-384-5464 Fax: 269-945-4495 Email: techsvcs@vikingcorp.com

Valve should stop. Proceed to step 6.

b. Pneumatic Release Systems:

- i. Close the Main Water Supply Control Valve (D.1) and Priming Valve (B.1)
- ii. Open Auxiliary Drain Valve (B.6)
- iii. Open all system main drains and auxiliary drains. Allow the system to drain completely Proceed to step 6.

6. Perform SEMI-ANNUAL maintenance. Refer to paragraph 6-C-2.

7. Place the system in service. Refer to paragraph 4-B.

NOTE: FLOW CONTROL VALVES SUPPLIED BY BRACKISH WATER, SALT WATER, FOAM, FOAM/WATER SOLUTION, OR ANY OTHER CORROSIVE WATER SUPPLY, SHOULD BE FLUSHED WITH GOOD QUALITY FRESH WATER BEFORE BEING RETURNED TO SERVICE.

8. Notify the Authority Having Jurisdiction that the test is complete. Record and/or provide notification of test results as required by the Authority Having Jurisdiction.

C. Maintenance (Refer to Figure 1)

NOTICE: THE OWNER IS RESPONSIBLE FOR MAINTAINING THE FIRE PROTECTION SYSTEM AND DEVICES IN PROPER OPERATING CONDITION. THE FLOW CONTROL VALVE MUST BE KEPT FROM FREEZING CONDITIONS AND PHYSICAL DAMAGE THAT COULD IMPAIR ITS OPERATION.

Where difficulty in performance is experienced, the valve manufacturer or his authorized representative shall be contacted if any field adjustment is to be made.

WARNING: ANY SYSTEM MAINTENANCE WHICH INVOLVES PLACING A CONTROL VALVE OR DETECTION SYSTEM OUT OF SERVICE MAY ELIMINATE THE FIRE PROTECTION CAPABILITIES OF THAT SYSTEM. PRIOR TO PROCEEDING, NOTIFY ALL AUTHORITIES HAVING JURISDICTION. CONSIDERATION SHOULD BE GIVEN TO EMPLOYMENT OF A FIRE PATROL IN THE AFFECTED AREAS.

1. After Each Operation:

- a. Sprinkler systems that have been subjected to a fire must be returned to service as soon as possible. The entire system must be inspected for damage, and repaired or replaced as necessary.
- b. Flow Control Valves and trim that have been subjected to brackish water, salt water, foam, foam/water solution, or any other corrosive water supply, should be flushed with good quality fresh water before being returned to service.
- c. Perform SEMI-ANNUAL maintenance after every operation.

2. Semi-Annual Maintenance:

- a. Remove the system from service. (See release system description and technical data for additional information.)
 - i. Close the Main Water Supply Control Valve (D.1) and Priming Valve (B.1).
 - ii. Open the Auxiliary Drain Valve (B.6). Allow the outlet chamber of the Flow Control Valve to drain completely.
 - iii. Release pressure in the priming chamber by opening the Emergency Release Valve (B.11).
- b. Inspect all trim for signs of corrosion and/or blockage. Clean and/or replace as required.
- c. Clean and/or replace all strainer screens.
- d. Refer to Item 4-B, INSTALLATION: PLACING THE VALVE IN SERVICE.

3. Every Fifth Year

- a. Internal inspection of Flow Control Valves is recommended every five years unless inspections and tests indicate more frequent internal inspections are required. Refer to DISASSEMBLY instructions provided below.
- b. Internal inspection of strainers, and restricted orifices is recommended every five years unless inspections and tests indicate more frequent internal inspections are required.
- c. Record and provide notification of inspection results as required by the Authority Having Jurisdiction.

4. Valve Disassembly

- a. Remove the valve from service. (Refer to Figure 1)
 - i. Close the Main Water Supply Control Valve (D.1) and Priming Valve (B.1).
 - ii. Open the Auxiliary Drain Valve (B.6).
 - iii. Release the pressure in the priming chamber by opening the Emergency Release Valve (B.11).
- b. Disconnect and remove trim and remove cap screws (10) to allow removal of cover (7). (Refer to Figure 5)
- c. Lift cover (7) from body (1) and spring (6) from clapper (8).
- d. Remove clapper assembly by lifting it from the body (1).
- e. Inspect seat (4). If replacement is necessary, do not attempt to separate it from body (1). Seat (4) is not removable.
- f. To replace diaphragm rubber (2), remove the circle of screws (3). Remove the clamp plate (9). Diaphragm rubber (2) can be removed.

	<h1 style="margin: 0;">TECHNICAL DATA</h1>	<p>FLOW CONTROL VALVE MODEL H-1 3" (DN80), 4" (DN100) & 6" (DN150)</p>
---	--	---

The Viking Corporation, 210 N Industrial Park Road, Hastings MI 49058

Telephone: 269-945-9501 Technical Services: 877-384-5464 Fax: 269-945-4495 Email: techsvcs@vikingcorp.com

- g. To replace the seat rubber assembly (13), the clapper assembly must be removed from the valve (see step 3 above). Remove the circle of screws (3). Seat rubber assembly (13) can be removed.

NOTE: PRIOR TO INSTALLING A NEW DIAPHRAGM RUBBER (2) OR SEAT RUBBER ASSEMBLY (8), MAKE CERTAIN THAT ALL SURFACES ARE CLEAN AND FREE OF FOREIGN MATTER. THE SEAT (9) MUST BE SMOOTH AND FREE OF NICKS, BURRS OR INDENTATIONS.

NOTE: THE DIAPHRAGM RUBBER MUST BE INSTALLED WITH THE RIDGE ON THE DIAPHRAGM RUBBER FACING TOWARDS THE CLAPPER.

5. Valve Reassembly

1. Prior to reassembly flush the valve of all foreign matter.
2. To reassemble, reverse disassembly procedure.

7. AVAILABILITY

The Viking Model H-1 Flow Control Valve is available through a network of domestic and international distributors. See the Viking Corp. Web site for closest distributor or contact The Viking Corporation.

8. GUARANTEES

For details of warranty, refer to Viking's current list price schedule or contact Viking directly.

**Maximum Allowable Pilot Heights for Select Equivalent Lengths of Hydraulic Release Piping
 Model H-1 Flow Control Valves with 1/8" (3,2 mm) Restricted Orifice**

Graph is based on 1/2" (15 mm) pilot sprinklers installed on 1/2" (15 mm) schedule 40 galvanized release system piping.
 If the maximum height of hydraulic release piping exceeds the limits shown on the graph, use Pneumatic or Electric Release System.

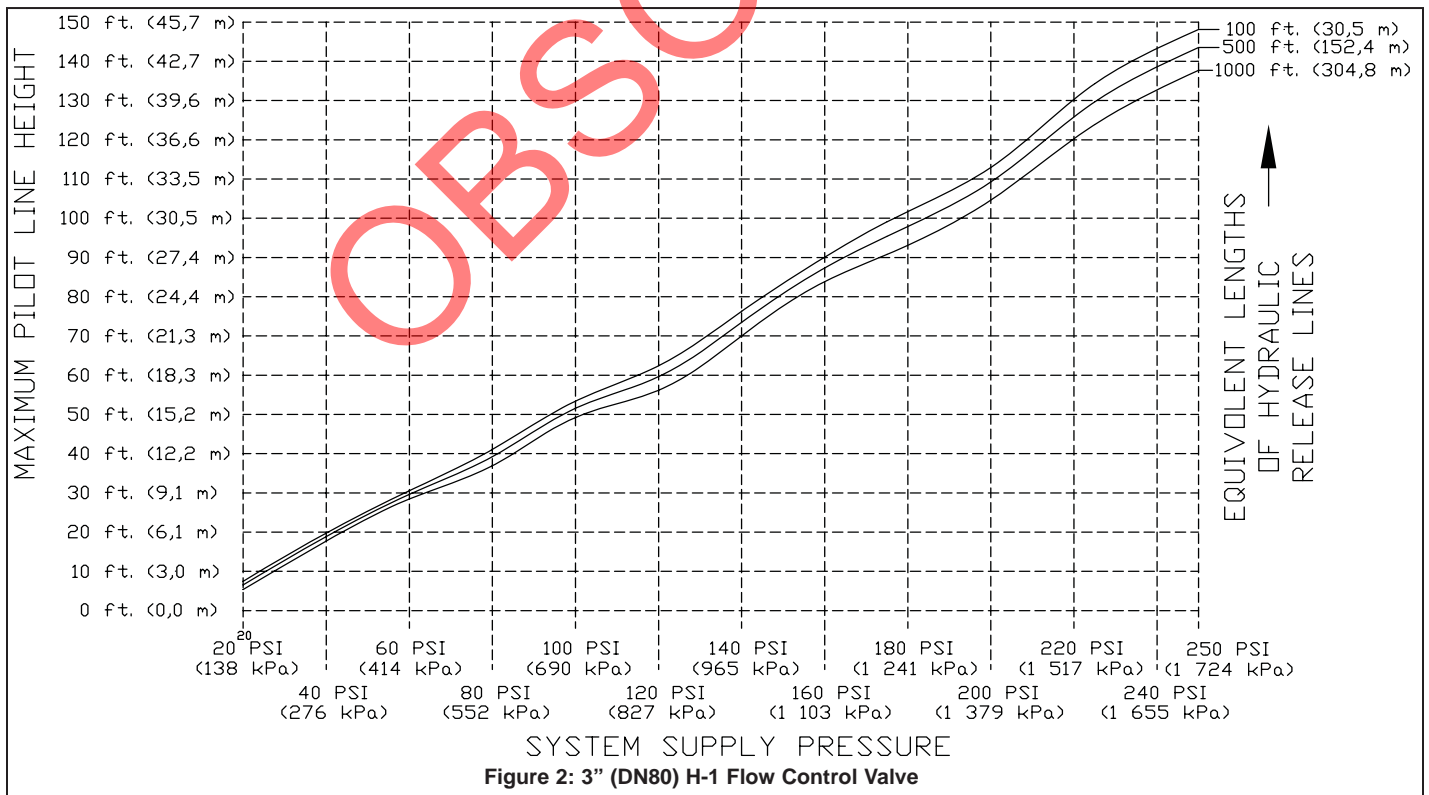



TECHNICAL DATA

**FLOW CONTROL VALVE
MODEL H-1**
3" (DN80), 4" (DN100) & 6" (DN150)

The Viking Corporation, 210 N Industrial Park Road, Hastings MI 49058
Telephone: 269-945-9501 Technical Services: 877-384-5464 Fax: 269-945-4495 Email: techsvcs@vikingcorp.com

Maximum Allowable Pilot Heights for Select Equivalent Lengths of Hydraulic Release Piping
Model H-1 Flow Control Valves with 1/8" (3,2 mm) Restricted Orifice
 Graph is based on 1/2" (15 mm) pilot sprinklers installed on 1/2" (15 mm) schedule 40 galvanized release system piping.
 If the maximum height of hydraulic release piping exceeds the limits shown on the graph, use Pneumatic or Electric Release System.

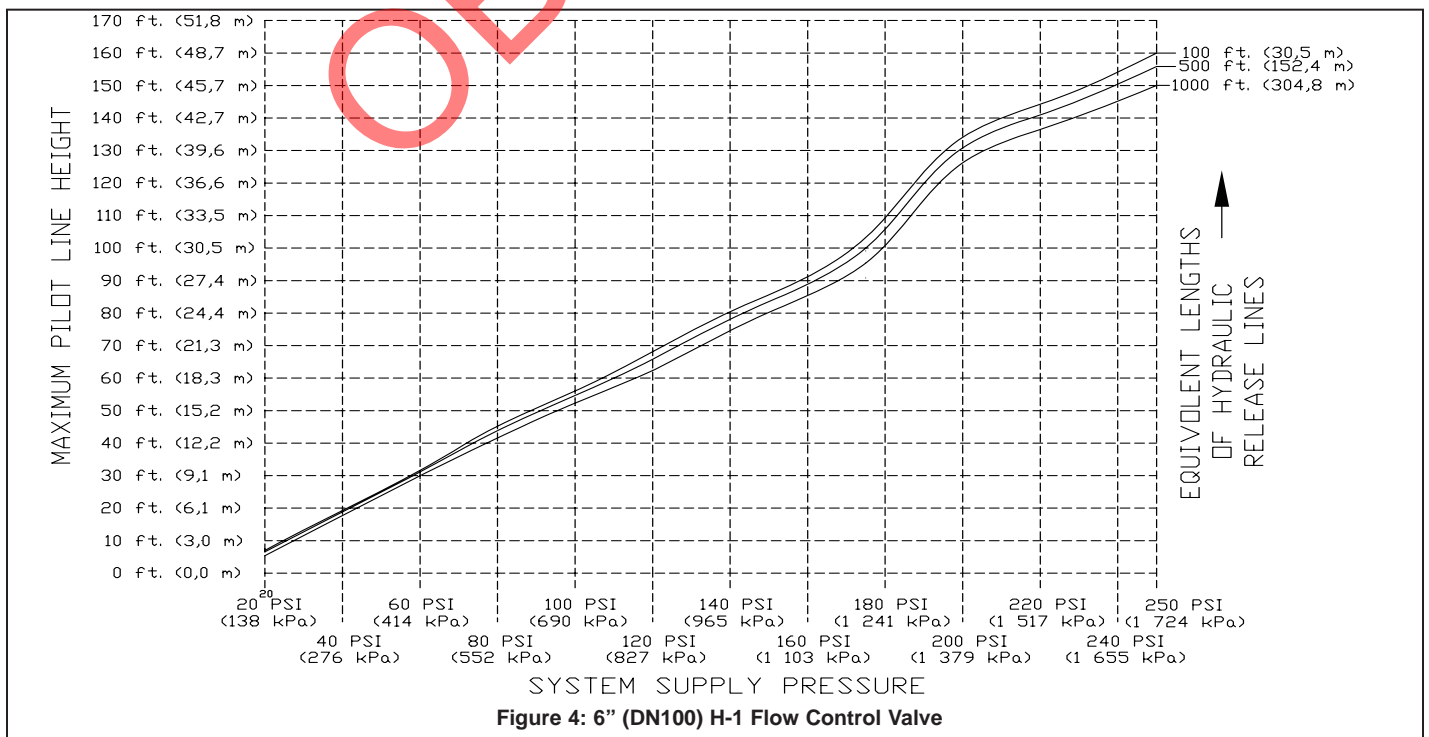
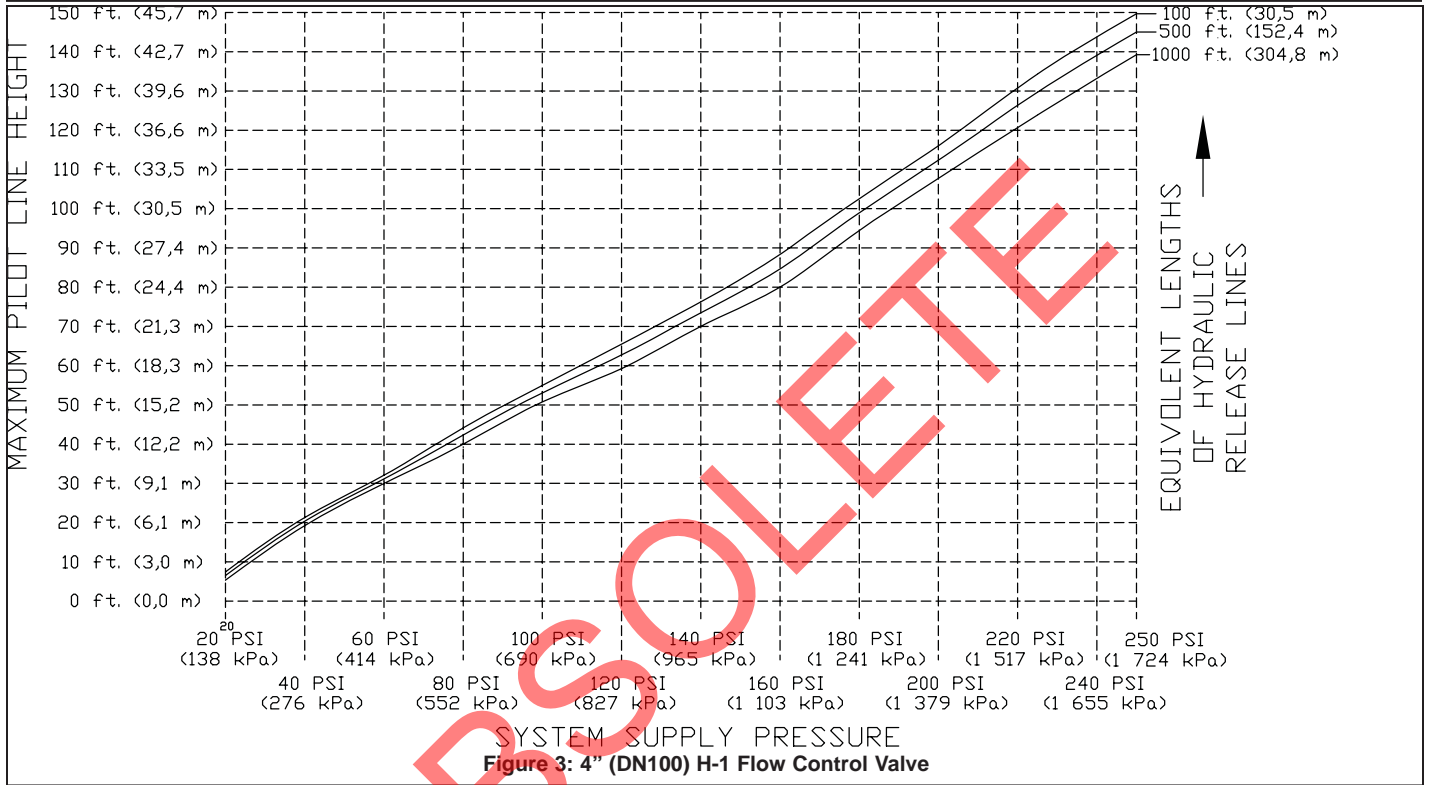



TECHNICAL DATA

FLOW CONTROL VALVE
MODEL H-1
3" (DN80), 4" (DN100) & 6" (DN150)

The Viking Corporation, 210 N Industrial Park Road, Hastings MI 49058
 Telephone: 269-945-9501 Technical Services: 877-384-5464 Fax: 269-945-4495 Email: techsvcs@vikingcorp.com

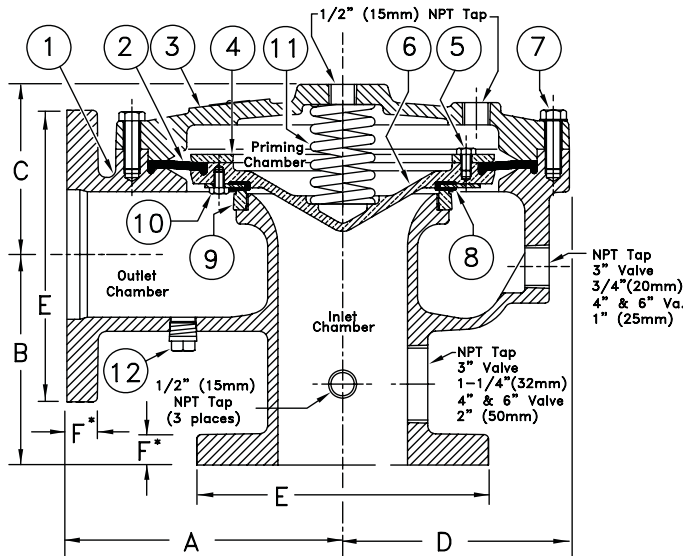

SIZE	A	B	C	D	E	F*	Dimensions shown in parentheses are mm.
3" (DN80)	7" (178)	5" (127)	4-1/4" (108)	5-3/8" (137)	7-1/2" (190,5)	3/4" (19,05)	* 4" & 6" valves are manufactured with sculptured flanges. Dimension indicates thickness of flange at bolt holes.
4" (DN100)	9" (229)	6-1/2" (165)	5-1/4" (133)	7" (178)	9" (228,6)	15/16" (23,81)	
6" (DN150)	12" (305)	8" (203)	7" (178)	9-1/8" (232)	11" (279,4)	1" (25,4)	

Figure 5

ITEM NO.	PART NUMBER			DESCRIPTION	MATERIAL	NO. REQ'D		
	3"	4"	6"			3"	4"	6"
1	--	--	--	Body	Ductile Iron 60-40-18	1	1	1
2	02492C	02377B	01974C	Diaphragm Rubber	EPDM	1	1	1
3	--	--	--	Cover	Ductile Iron 60-40-18	1	1	1
4	02493B	02378B	05704B	Clamp Ring	Bronze UNS-C84400	1	1	1
5	02494A			Screw, R.H., No. 10-24 x 1/2" (12,7mm) lg.	Stainless Steel UNS-S30200	6		
		08217		Screw, H.H.C., 5/16" - 18 X 1/2" (12,7mm) lg.	Stainless Steel UNS-S30200		8	
			02454A	Screw, H.H.C., 3/8"-16 x 5/8" (15,9mm) lg.	Stainless Steel UNS-S30200			12
6	08846N	08844N	08570N	Clapper	Ductile Iron 65-45-12 Teflon® Coated	1	1	1
7	02169A			Screw, H.H.C., 1/2"-13 x 1-1/4" (31,8mm) lg.	Steel	10		
		02200A		Screw, H.H.C., 1/2"-13 x 1-1/2" (38,1mm) lg.	Steel		12	
			05707A	Screw, H.H.C., 5/8"-11 x 1-3/4" (44,5mm) lg.	Steel			15
8	02497B	02382B	02176B	Seat Rubber Assembly	EPDM/Stainless Steel UNS-S30400	1	1	1
9	--	--	--	Seat	Bronze UNS-C84400	1	1	1
10	02496A			Screw, R.H., 10-24 x 3/8" (9,5mm) lg.	Stainless Steel	6		
		08217		Screw, H.H.C., 5/16" - 18 X 1/2" (12,7mm) lg.	Stainless Steel		8	
			07932	Screw, H.H.C., 3/8"-16 x 1/2" (12,7mm) lg.	Stainless Steel			12
11	05838A	05842A	01920A	Spring	Stainless Steel	1	1	1
12	--	--	--	Plug, 1/2" NPT	Steel	1	1	1
13	--	--	--	Vent Screw	Stainless Steel	0	1	1
14	--	--	--	Vent Screw Washer	Stainless Steel	0	1	1
--Indicates replacement part not available								
SUB-ASSEMBLY								
2, 4-8 10	13397	13399	13482	Clapper Assembly Kit				

THIS PAGE
INTENTIONALLY
LEFT BLANK

OBSOLETE